



PARTS CATALOGUE

DR2E18 4-PASS (J1H1) OTHERS



NEWS No.	DATE	COMMENT
PE0-GC-200010	May.,15,2020	COR:HEAD & TAIL LIGHT ILLUSTRATION CORRECTION

1TJ1H-400E1

()

2020/06/05

DR2E18 4-PASS
PARTS CATALOGUE
©2020 by Yamaha Motor Co., Ltd.
1st edition, June 2020
All rights reserved.
Any reprinting or unauthorized use
without the written permission of
Yamaha Motor Co., Ltd.
is expressly prohibited.
Printed in Japan.

FOREWORD

This Parts Catalogue is related to the parts for the model(s) on the cover page. When you are ordering replacement parts, please refer to this Parts Catalogue and quote both part numbers and part names correctly.

1. Modifications or additions which have been made after the issue of the Parts Catalogue will be announced in the Parts News.
It is advisable that you make the necessary corrections to the Parts Catalogue according to the Parts News.
2. Abbreviations
The following abbreviations are used in this Parts Catalogue.
“UR” Use specified parts number.
“UN” Use as many as needed.
“AP” Alternate Parts
“LM” Locally Made (Parts need to be ordered locally)
“F#” Frame No. (Applicable machine No.)
“O/S” Over Size
3. The number of components for assembly
 - Parts, which are to be supplied in an assembly, are listed with a dot (.) in front of the part name as shown below.
 - The numeral appearing to the right of each component part indicates the quantity of parts for each assembly unit.

PART NO.	DESCRIPTION	Q'TY	REMARKS
2F5-83310-60	FRONT FLASHER LIGHT ASSY	2	
115-83311-60	.BULB (6V-18W)	1	

4. Applicable colours of graphics are represented in the “REMARKS” as shown below.

PART NO.	DESCRIPTION	Q'TY	REMARKS
2N4-24110-00-X5	FUEL TANK COMP.	2	MXR
3J1-24240-10	.GRAPHIC, FUEL TANK	1	FOR MXR

5. Note that the illustrations for reference in finding parts numbers are not to be used for assembling. When assembling, please use the applicable service manual.

6. The asterisk (*) before a reference number indicates modified items after the first edition.

FOREWORD

7. Applicable Serial No.

Frame Serial No.

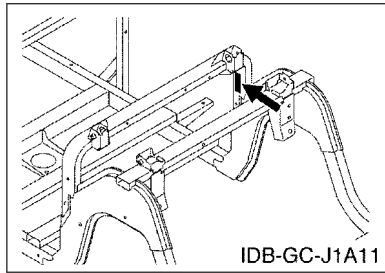

8. Applicable Colour Code (The (*) mark shows Model colour.)

Abbreviation	Colour Name	Colour Code
BW1(*)	BLUISH WHITE 1	1571
DNGM3(*)	DARK GRAYISH GREEN METALLIC 3	0712
DPBMU(*)	DARK PURPLISH BLUE METALLIC U	0996
DRMK(*)	DEEP RED METALLIC K	0918
LYNM9(*)	LIGHT YELLOWISH GRAY ME 9	0752
SM1(*)	SILVER METALLIC 1	0660

9. Quantity Column Information

Column No.	Name Of Q'ty Column	Destination
1	J1H1	OTHERS

10. Applicable Starting Serial No.

Frame Serial No.

Serial No.	Name Of Q'ty Column	Model Code
J1H-101001	J1H1	J1H1

CONTENTS

BODY

REAR ARM & SUSPENSION.....	1
FRAME.....	2
FRONT SUSPENSION.....	4
STEERING.....	6
PEDAL WIRE.....	8
PEDAL ASSEMBLY.....	9
BRAKE.....	12

DRIVE

TRANSAXLE.....	13
WHEEL.....	15

R/G

WINDSHIELD.....	16
BUMPER.....	17
BODY.....	18
BODY 2.....	20
BODY 3.....	21
BODY FITTING.....	22
SUN ROOF.....	23
CARRIER.....	24
REAR VIEW MIRROR.....	25
SEAT.....	26

ELECTRICAL

ELECTRIC MOTOR.....	28
HEAD & TAIL LIGHT.....	29
CONTROLLER 1.....	31
ELECTRICAL 1.....	32
BATTERY CHARGER.....	34

INDEX

NUMERICAL INDEX.....	35
----------------------	----

FIG. 1 REAR ARM & SUSPENSION

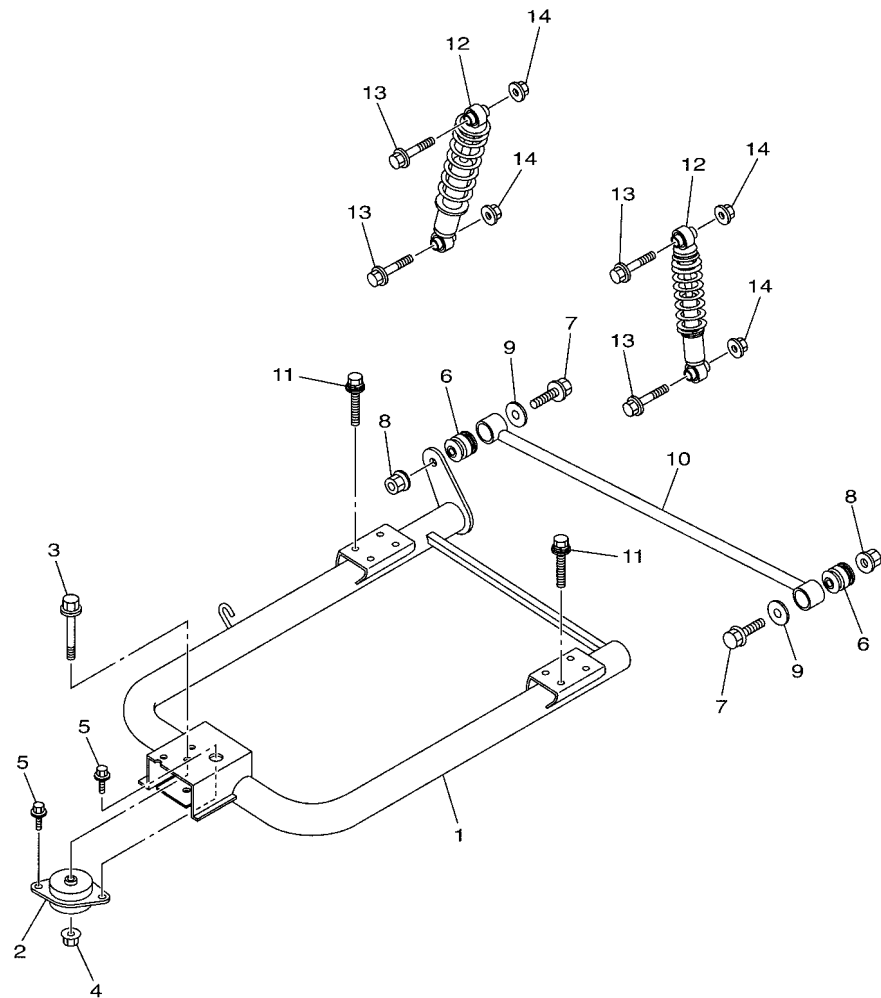

J1B1400-S010

REF. NO.	PART NO.	DESCRIPTION	J1H				REMARKS
1	J1B-F2110-00	REAR ARM COMP.	1				
2	JX4-22123-00	BUSH 1	1				
3	90105-12031	BOLT, FLANGE	1				
4	95602-12200	NUT, SELF-LOCKING	1				
5	95812-10016	BOLT, FLANGE	2				
6	JN6-F2124-10	BUSH 2	2				
7	95812-12065	BOLT, FLANGE	2				
8	95602-12200	NUT, SELF-LOCKING	2				
9	90201-12426	WASHER, PLATE	2				
10	J1A-F217G-00	ROD, CONNECTING 2	1				
11	97512-10620	BOLT, WITH WASHER	8				
12	JW6-F2210-01	SHOCK ABSORBER ASSY, REAR	2				
13	95812-10055	BOLT, FLANGE	4				
14	95602-10200	NUT, S/L FLANGE	4				

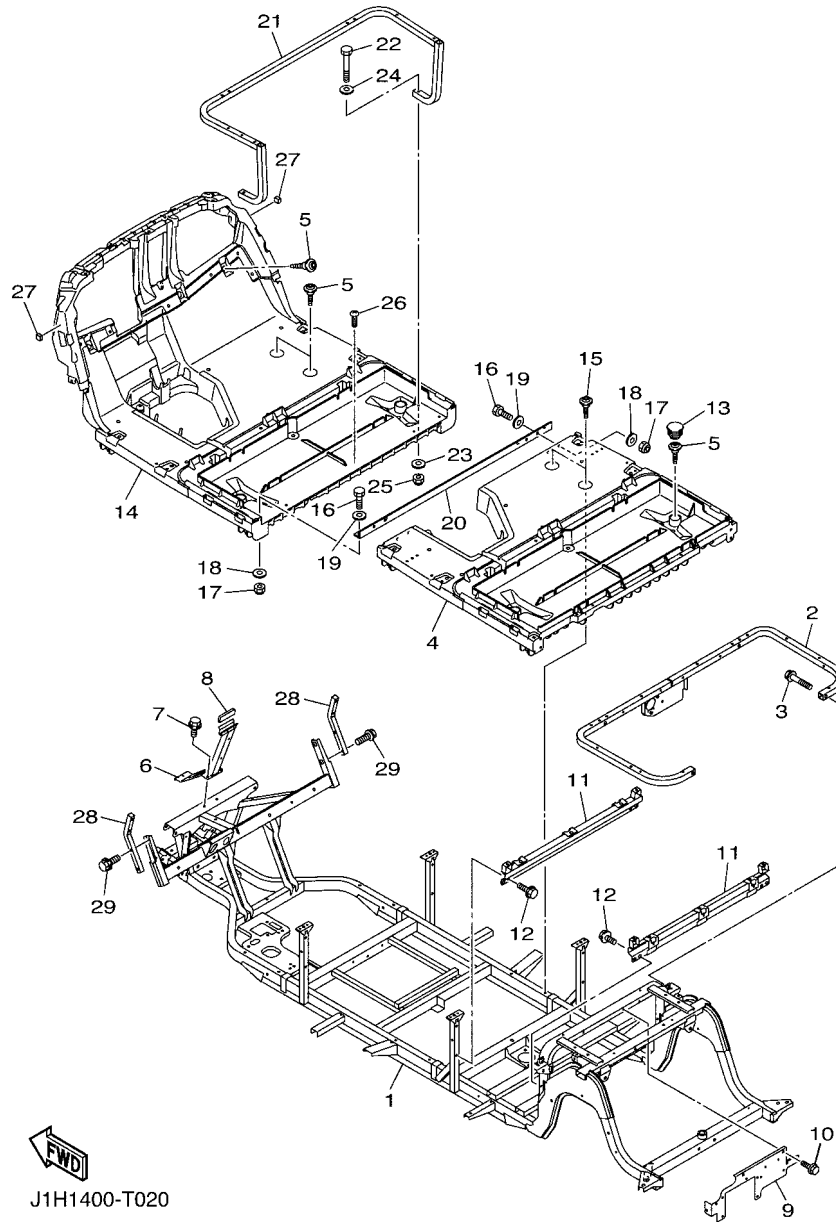
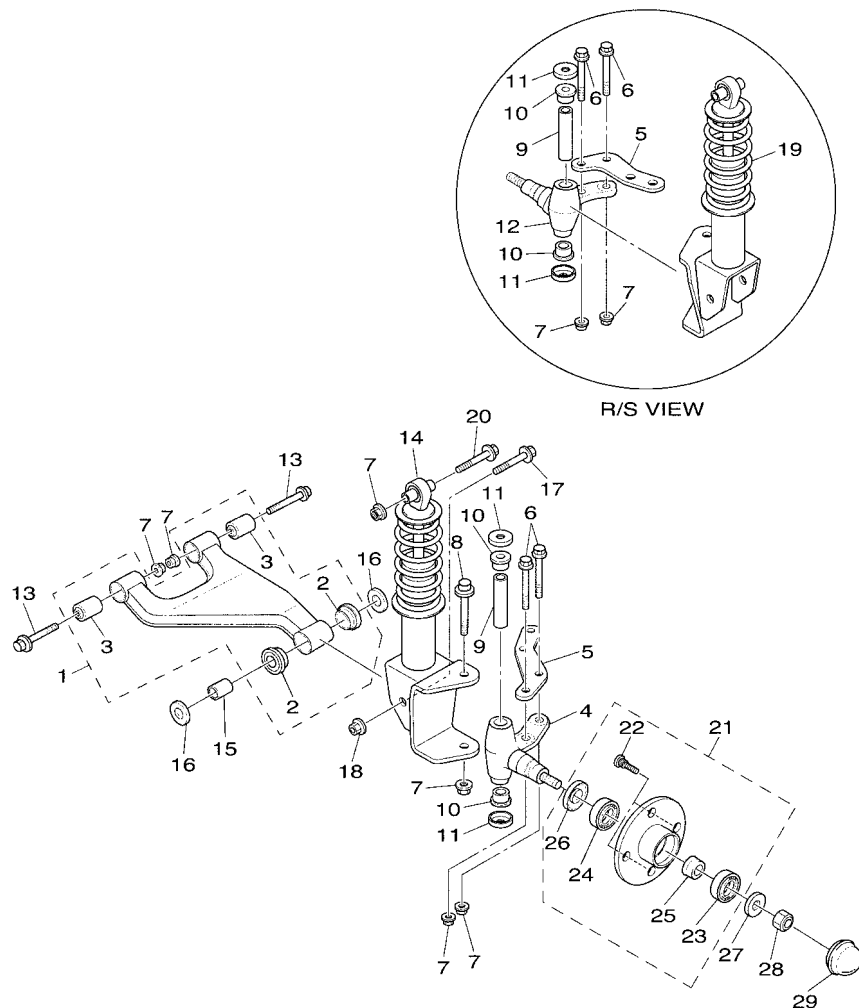

FIG. 2 FRAME

REF. NO.	PART NO.	DESCRIPTION	J1H				REMARKS
1	J1F-F2501-00	FRAME COMP.	1				
2	J1B-F255G-00	MEMBER, SEAT SUPPORT	1				
3	95812-08040	BOLT, FLANGE	2				
4	J1E-F7411-20	FOOTREST 1	1				
5	J0B-F1738-00	BOLT	9				
6	J1B-F258E-00	SUPPORT, FRONT COWL	1				
7	95822-08016	BOLT, FLANGE	2				
8	J1B-F2127-00	SHIM	1				
9	J1C-F252M-00	BRACKET, 3	1				
10	95822-06016	BOLT, FLANGE	2				
11	J1A-F2535-01	STAY, BATTERY 1	2				
12	95822-08016	BOLT, FLANGE	4				
13	JW9-F2417-00	PLUG	2				
14	J1E-F7411-00	FOOTREST 1	1				
15	J0B-F1738-00	BOLT	4				
16	97027-06025	BOLT, HEXAGON	8				
17	95680-06100	NUT, U	8				
18	90201-06020	WASHER, PLATE	8				
19	92990-06200	WASHER, PLAIN	8				
20	J1E-F7452-00	BRACKET, FOOTREST 1	1				
21	J1E-F255G-00	MEMBER, SEAT SUPPORT	1				
22	97027-06050	BOLT, HEXAGON	2				
23	90201-06020	WASHER, PLATE	2				
24	92990-06200	WASHER, PLAIN	2				
25	95680-06100	NUT, U	2				
26	97702-40525	SCREW, TAPPING	1				
27	J1B-K821A-00	PAD, BODY MOUNTING1	2				

FIG. 3 FRONT SUSPENSION



J1B1400-S030

REF. NO.	PART NO.	DESCRIPTION	J/H				REMARKS
1	JU0-F3570-20	FRONT LOWER ARM COMP.	2				
2	90381-18001	.BUSH, SOLID	2				
3	2HR-23526-00	.BUSH	2				
4	JU0-F3511-10	KNUCKLE, STEERING 1	1				
5	JW1-F3512-00	ARM, KNUCKLE 1	2				
6	90105-10373	BOLT, FLANGE	4				
7	95602-10200	NUT, S/L FLANGE	12				
8	90105-10219	BOLT, FLANGE	2				
9	2NL-23448-00	SPACER	2				
10	90381-17800	BUSH, SOLID	4				
11	2NL-23517-00	COVER, THRUST 1	4				
12	JU0-F3521-10	KNUCKLE, STEERING 2	1				
13	90105-10267	BOLT, FLANGE	4				
14	J0C-F3350-00	SHOCK ABSORBER ASSY	1				
15	90387-12016	COLLAR	2				
16	J1A-F2128-00	COVER, THRUST 1	4				
17	95812-12080	BOLT, FLANGE	2				
18	95612-12100	NUT, U	2				
19	J0C-F3390-00	SHOCK ABSORBER ASSY 2	1				
20	90105-10267	BOLT, FLANGE	2				
21	JC1-F5103-00	HUB BEARING UNIT ASSY	2				
22	90114-12004	.BOLT, SERRATION	4				
23	93306-20437	.BEARING	1				
24	93306-005Y3	.BEARING	1				
25	90387-241M7	.COLLAR	1				
26	93102-30803	.OIL SEAL	1				
27	90209-32271	WASHER	2				

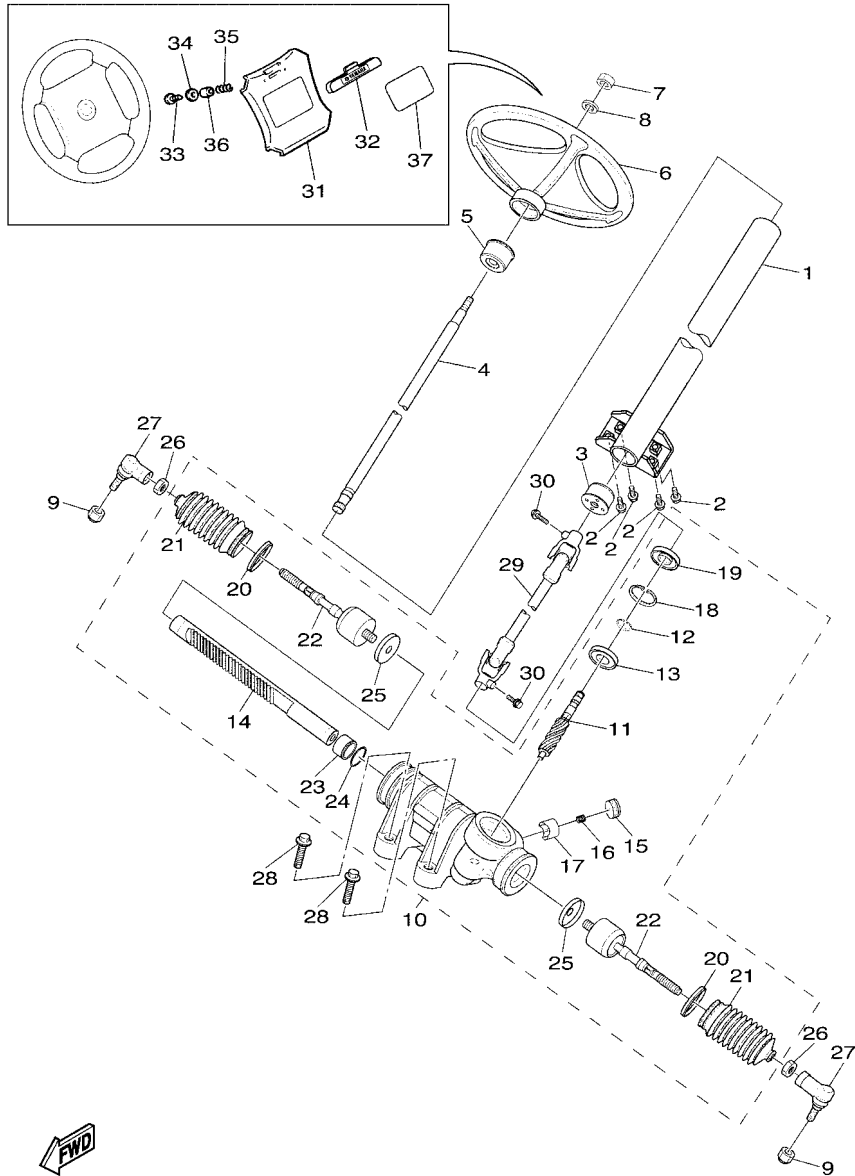

J1A1400-R040

FIG. 4 STEERING

REF. NO.	PART NO.	DESCRIPTION	JTH				REMARKS
1	JW1-F3811-03	COLUMN, STEERING	1				
2	95812-08020	BOLT, FLANGE	4				
3	JU0-F3857-11	HOLDER	1				
4	JU0-F3828-10	ROD, STEERING	1				
5	JU0-F3857-11	HOLDER	1				
6	JN3-F3838-00	WHEEL, STEERING	1				
7	90185-12008	NUT, SELF-LOCKING	1				
8	92902-12200	WASHER	1				
9	95602-12200	NUT, SELF-LOCKING	2				
10	J1A-23400-00	STEERING ASSY	1				
11	J1A-2387A-00	.GEAR, PINION	1				
12	JX4-2384N-00	.CLIP, RING	1				
13	JX4-23812-00	.BEARING, STEERING	1				
14	J1A-2387E-00	.GEAR, RACK	1				
15	JR7-2387G-00	.COVER, ADJUST	1				
16	JR7-2387K-00	.SPRING, PRESSURE	1				
17	JR7-2387F-00	.PAD, PRESSURE	1				
18	JR7-2387J-00	.RING, STOPPER	1				
19	JR7-23844-00	.SEAL	1				
20	J1A-23489-00	.BAND	2				
21	J1A-23527-00	.SEAL, DUST 1	2				
22	J1A-23837-00	.ROD, TIE 2	2				
23	JR7-2467K-00	.BUSH CAP	1				
24	JR7-23866-00	.RING, SNAP	1				
25	JR7-23894-00	.WASHER, LOCK 1	2				
26	1P0-F3833-00	NUT 1	2				
27	J1A-F3841-00	JOINT, UNIVERSAL 1	2				

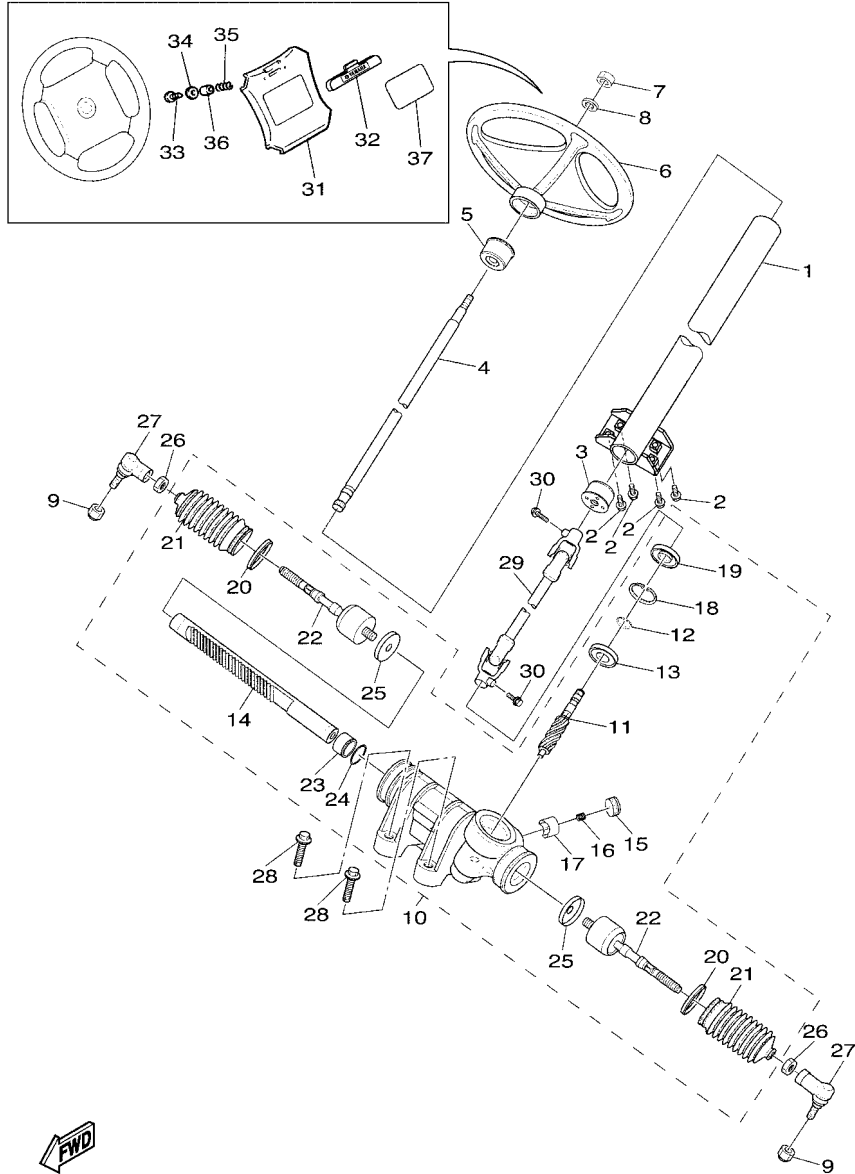

J1A1400-R040

FIG. 4 STEERING

REF. NO.	PART NO.	DESCRIPTION	JTH				REMARKS
28	95812-10040	BOLT, FLANGE	4				
29	J1A-23822-00	JOINT 1	1				
30	97512-08530	BOLT, WITH WASHER	2				
31	JW8-K8357-00	HOLDER 1	1				
32	JN6-K8358-01	HOLDER 2	1				
33	97702-40525	SCREW, TAPPING	2				
34	90201-044H9	WASHER, PLATE	2				
35	90502-10013	SPRING, CONICAL	2				
36	90387-046N7	COLLAR	2				
37	JW8-K7762-00	LABEL, WARNING 2	1				

FIG. 5 PEDAL WIRE

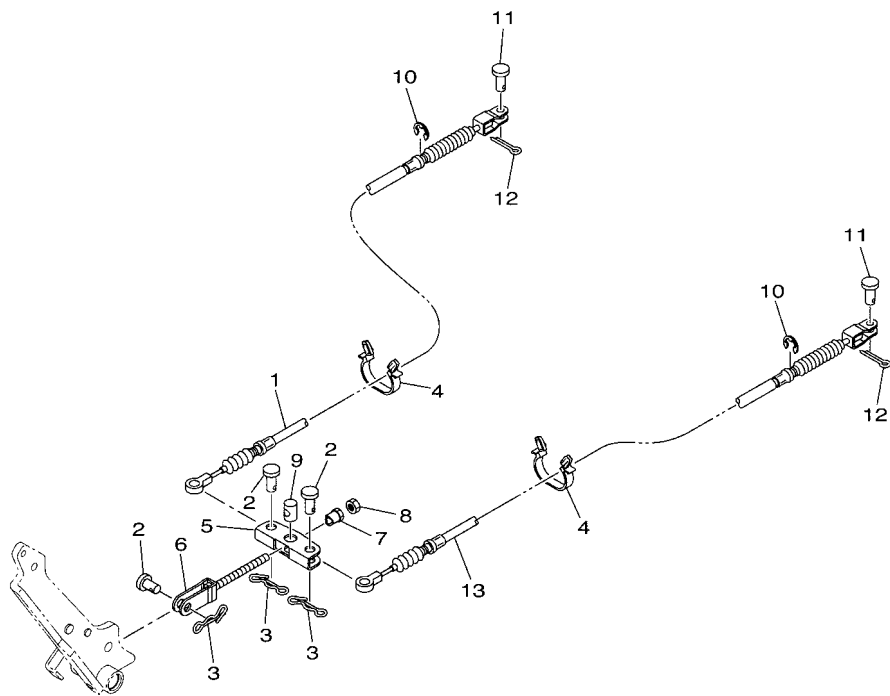

REF. NO.	PART NO.	DESCRIPTION	J1H1				REMARKS
1	J1F-F6351-00	CABLE, BRAKE	1				
2	91702-10026	PIN, CLEVIS	3				
3	90468-20196	CLIP	3				
4	90464-24230	CLAMP	3				
5	JW8-F5681-10	EQUALIZER, BRAKE	1				
6	JN6-F5685-01	ROD	1				
7	90179-08261	NUT	1				
8	95307-08700	NUT	1				
9	90249-14129	PIN	1				
10	99002-09600	CIRCLIP	2				
11	91702-08018	PIN, CLEVIS	2				
12	91490-25015	PIN, COTTER	2				
13	J1F-F6341-00	WIRE, BRAKE 1	1				



J1E1400-S050

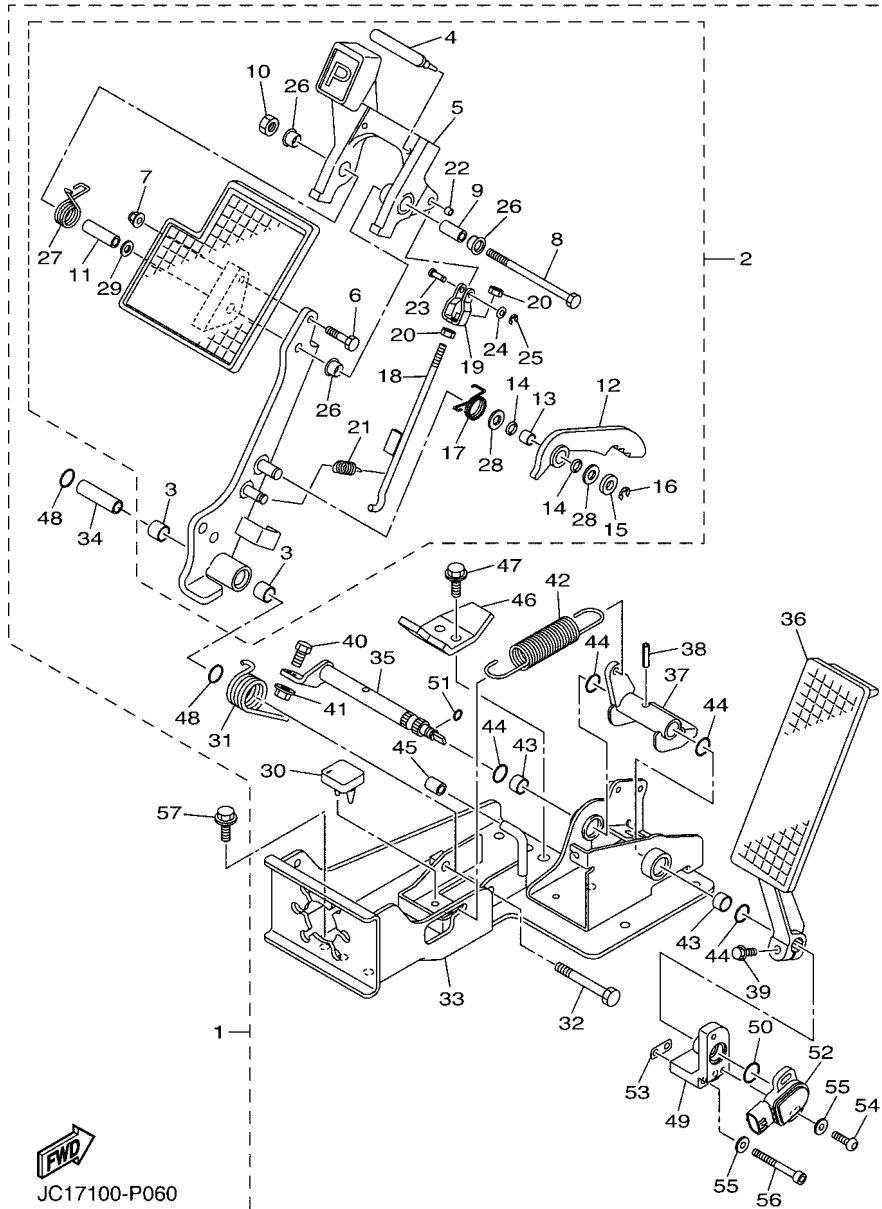
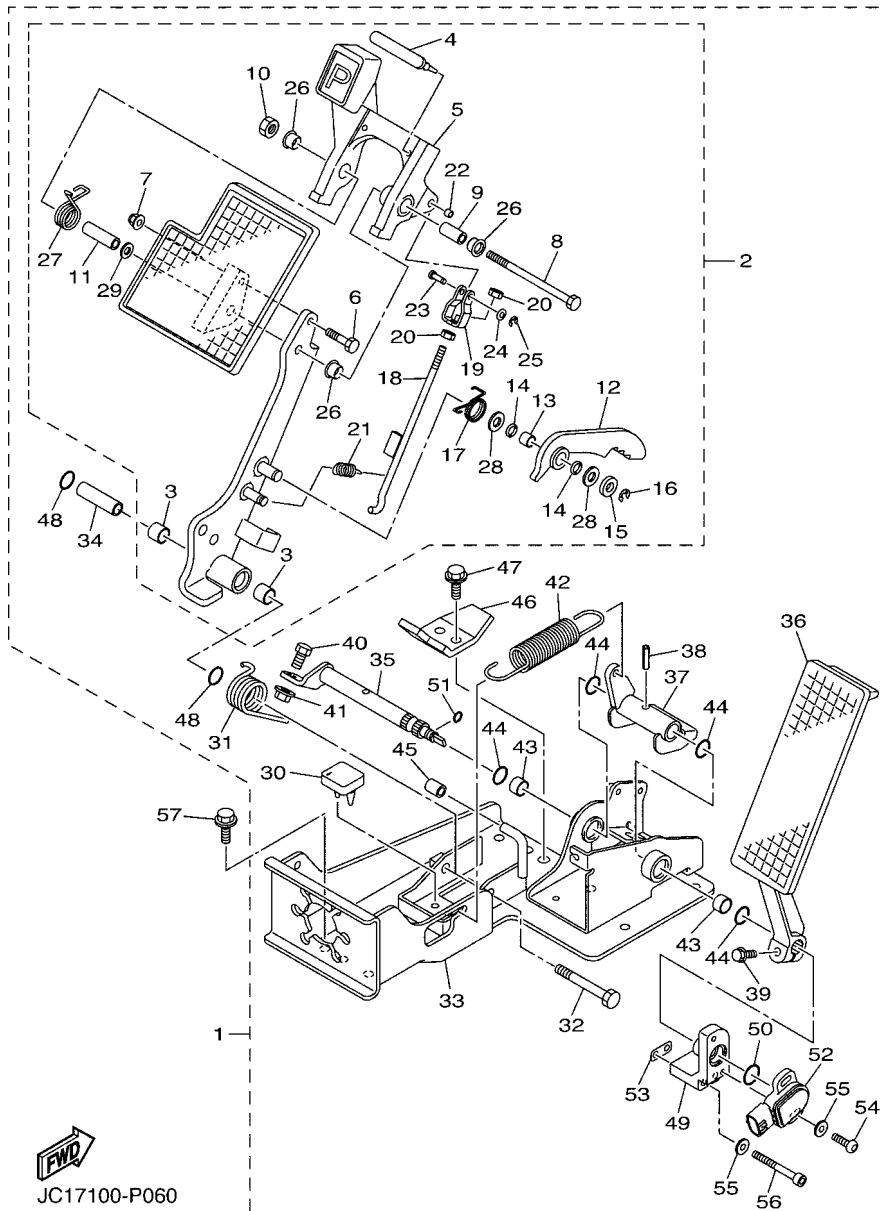

FIG. 6 PEDAL ASSEMBLY

REF. NO.	PART NO.	DESCRIPTION	JTH	REMARKS
1	JW9-F7850-31	PEDAL ASSY (L.H)	1	
2	JW9-F7200-21	.PEDAL, BRAKE	1	
3	JW8-F7814-21	.BUSH, PEDAL	2	
4	JW9-F5672-00	..PAD, PARKING PEDAL	1	
5	JW9-F5671-00	..PEDAL, PARKING BRAKE	1	
6	JW8-F7117-00	..BOLT, MAIN STAND	1	
7	JW8-F8363-00	..NUT	1	
8	JW8-F7416-00	..BOLT, FOOTREST	1	
9	JW8-F639N-00	..COLLAR	1	
10	JW8-F7218-00	..NUT	1	
11	JW8-F7113-00	..COLLAR, MAIN STAND	1	
12	JW9-F5666-00	..SECTOR, PARKING BRAKE	1	
13	JW8-F7121-00	..BUSH	1	
14	JW9-F7221-00	..SEAL, SHAFT	2	
15	JW8-F7322-00	..WASHER	1	
16	JW8-F3183-00	..CIRCLIP	1	
17	JW8-F7426-01	..SPRING, RETURN	1	
18	JW9-F7231-10	..ROD, BRAKE	1	
19	JW9-F7232-00	..END, ROD 2	1	
20	JW8-F7318-00	..NUT	2	
21	JW8-F6314-00	..SPRING	1	
22	JW8-F639L-00	..BUSH 1	1	
23	JW9-F7228-00	..PIN, JOINT	1	
24	JW8-F8323-00	..WASHER, LEG SHIELD	1	
25	JW8-F5415-00	..CIRCLIP	1	
26	90386-12800	..BUSH	3	
27	JW8-F7825-01	..SPRING, RETURN	1	



JC17100-P060

FIG. 6 PEDAL ASSEMBLY

REF. NO.	PART NO.	DESCRIPTION	J/H				REMARKS
28	JW8-F7119-00	..WASHER	2				
29	JW8-F8319-00	..WASHER	1				
30	JW9-F7245-10	.PAD, BRAKE PEDAL	1				
31	JW8-F7316-01	.SPRING, SIDE STAND	1				
32	JW8-F7217-00	.BOLT	1				
33	JW9-F7445-31	.PLATE 1	1				
34	JW8-F7213-20	.COLLAR	1				
35	JW9-F7853-00	.SHAFT, PEDAL 1	1				
36	JW9-F7871-10	.PEDAL, ACCELERATOR	1				
37	JW9-F7872-20	.ARM, ACCELERATOR PEDAL	1				
38	JW8-F7438-00	.PIN, CLEVIS	1				
39	JW8-F7434-00	.BOLT	1				
40	JW8-F7317-00	.BOLT	1				
41	JW8-F7118-00	.NUT	1				
42	JW8-F815H-01	.SPRING	1				
43	JW8-F7814-21	.BUSH, PEDAL	2				
44	JW8-F4486-00	.O-RING	4				
45	JW9-F5673-00	.DAMPER, BRAKE	1				
46	JW9-F7246-20	.NAIL, BRAKE	1				
47	JW8-F8331-00	.BOLT, LEG SHIELD	2				
48	JW8-F4486-00	.O-RING	2				
49	JW9-F7263-00	.BRACKET 1	1				
50	JW9-F4648-20	.O-RING	1				
51	JW8-F41B8-00	.O-RING	1				
52	JW9-H5885-00	.THROTTLE SENSOR ASSY	1				
53	JW9-F5827-00	.SHIM, CALIPER	1				UR T: 0.5 MM
	JW9-F5827-10	.SHIM, CALIPER	1				UR T: 0.9 MM

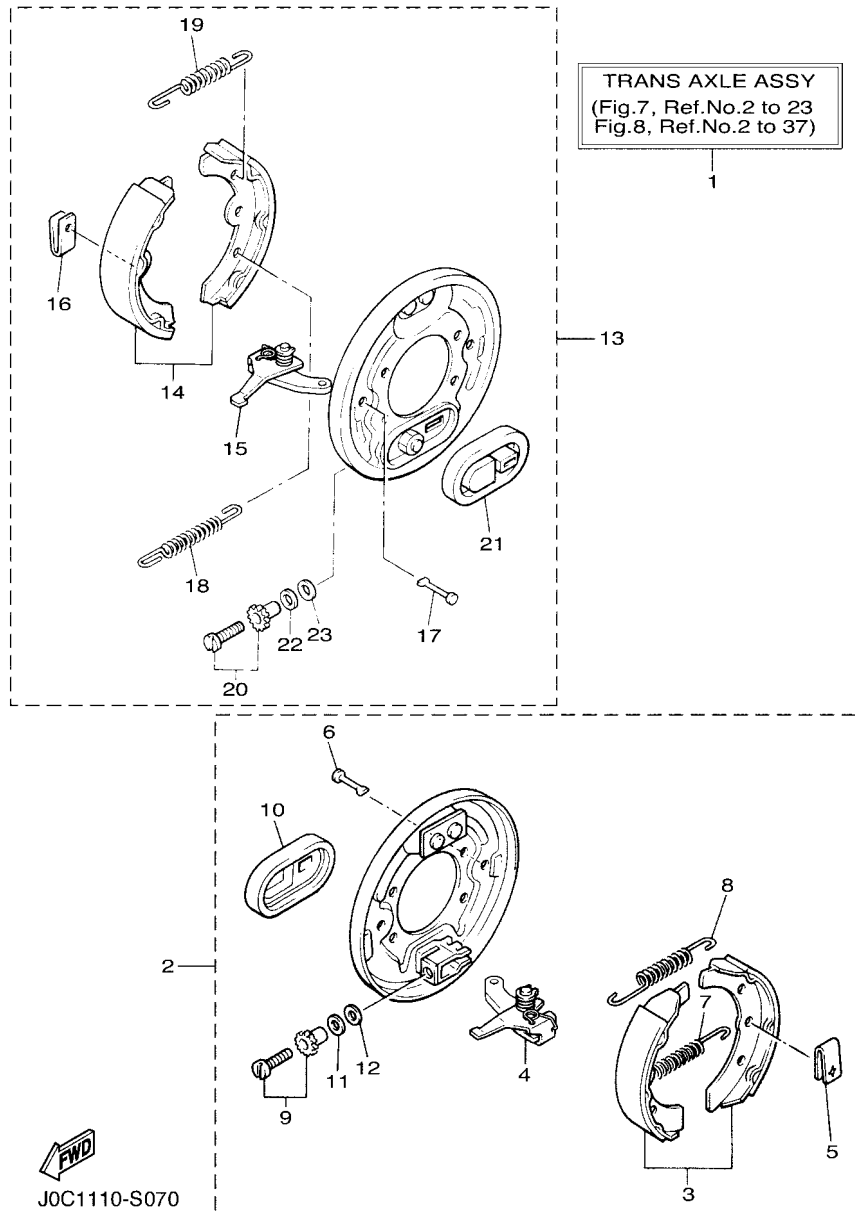
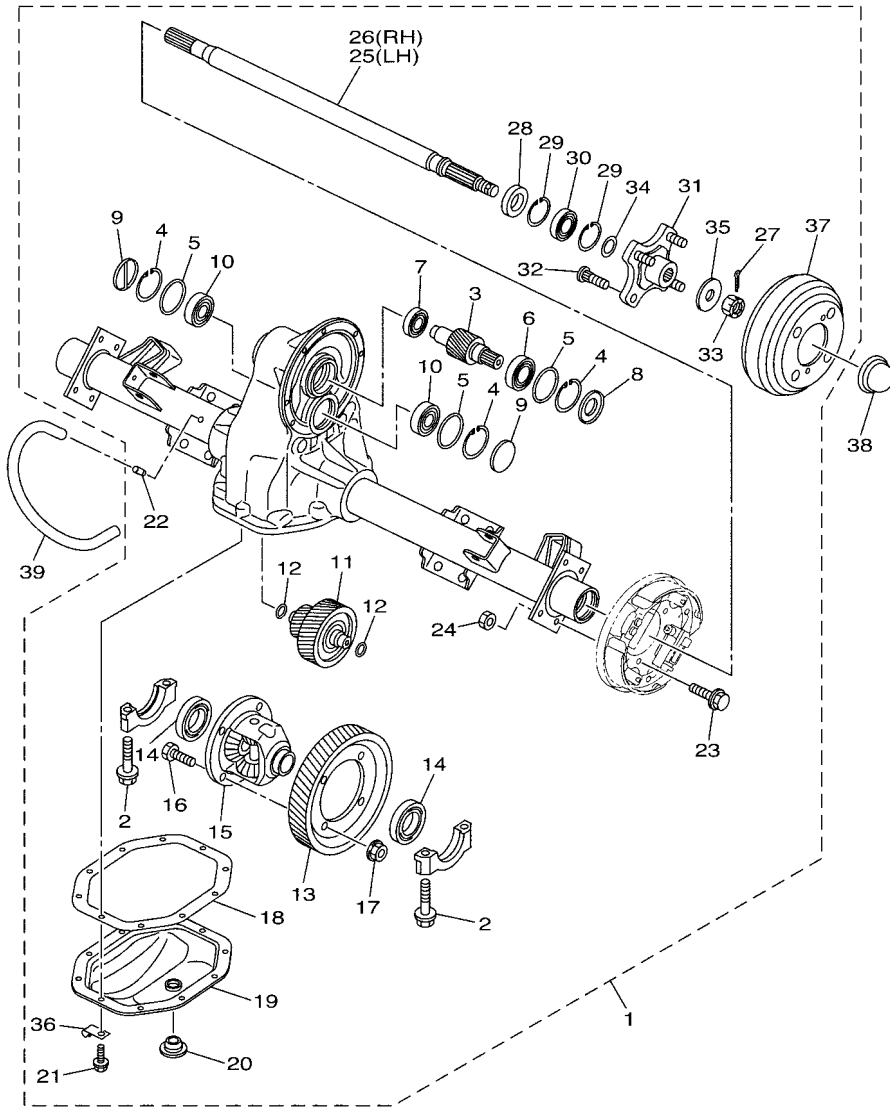

FIG. 7 BRAKE

REF. NO.	PART NO.	DESCRIPTION	J/H				REMARKS
1	J0C-G6300-01	TRANS AXLE ASSY	1				
2	JW8-F7290-10	..BACKING PLATE ASSY 2	1				
3	JN9-W2536-11	..BRAKE SHOE SET	1				
4	J38-27205-00	..LEVER ASSY 2	1				
5	JW8-F7281-00	..SPRING, SHOE CLAMP	2				
6	J10-27282-00	..PIN, SHOE HOLD DOWN	2				
7	90506-20281	..SPRING, TENSION	1				
8	90506-14001	..SPRING, TENSION	1				
9	J55-27260-00	..ADJUSTER ASSY	1				
10	JW8-F7286-00	..COVER, DUST	1				
11	90201-121H9	..WASHER, PLATE	1				
12	90201-121H8	..WASHER, PLATE	1				
13	JW8-F7280-10	..BACKING PLATE ASSY 1	1				
14	JN9-W2536-11	..BRAKE SHOE SET	1				
15	J38-27204-00	..LEVER ASSY 1	1				
16	JW8-F7281-00	..SPRING, SHOE CLAMP	2				
17	J10-27282-00	..PIN, SHOE HOLD DOWN	2				
18	90506-20281	..SPRING, TENSION	1				
19	90506-14001	..SPRING, TENSION	1				
20	J55-27270-00	..ADJUSTER ASSY	1				
21	JW8-F7286-00	..COVER, DUST	1				
22	90201-121H9	..WASHER, PLATE	1				
23	90201-121H8	..WASHER, PLATE	1				



J0C1110-S080

FIG. 8 TRANSAXLE

REF. NO.	PART NO.	DESCRIPTION	J/H				REMARKS
1	J0C-G6300-01	TRANS AXLE ASSY	1				
2	90105-10840	.BOLT, FLANGE	4				
3	JW9-G6321-00	.SHAFT, INPUT	1				
4	93420-50804	.CIRCLIP	3				
5	93210-478B8	.O-RING	3				
6	93306-005Y1	.BEARING	1				
7	93306-203X1	.BEARING	1				
8	JW9-G6136-00	.SEAL 1	1				
9	JH7-G3396-01	.PLUG, BLIND	2				
10	93306-303Y6	.BEARING	2				
11	JW9-G6350-00	.COUNTER GEAR ASSY	1				
12	93210-148B9	.O-RING	2				
13	JW9-G6421-00	.GEAR, RING	1				
14	93306-007Y0	.BEARING	2				
15	JW9-G6410-00	.DIFFERENTIAL ASSY.	1				
16	90101-10854	.BOLT	4				
17	90170-10840	.NUT	4				
18	JW9-G631A-00	.GSKT., CASE	1				
19	JW9-G6312-00	.CASE, TRANSMISSION 2	1				
20	JN3-G6432-00	.STOPPER	1				
21	90101-08856	.BOLT	10				
22	JW8-G5378-00	.NIPPLE, HOSE	1				
23	90101-08855	.BOLT	8				
24	90170-08841	.NUT	8				
25	JR1-G6511-00	.SHAFT, REAR AXLE 1 (L.H)	1				
26	JR1-G6512-00	.SHAFT, REAR AXLE 2 (R.H)	1				
27	91490-30030	.PIN. COTTER	2				

FIG. 8 TRANSAXLE

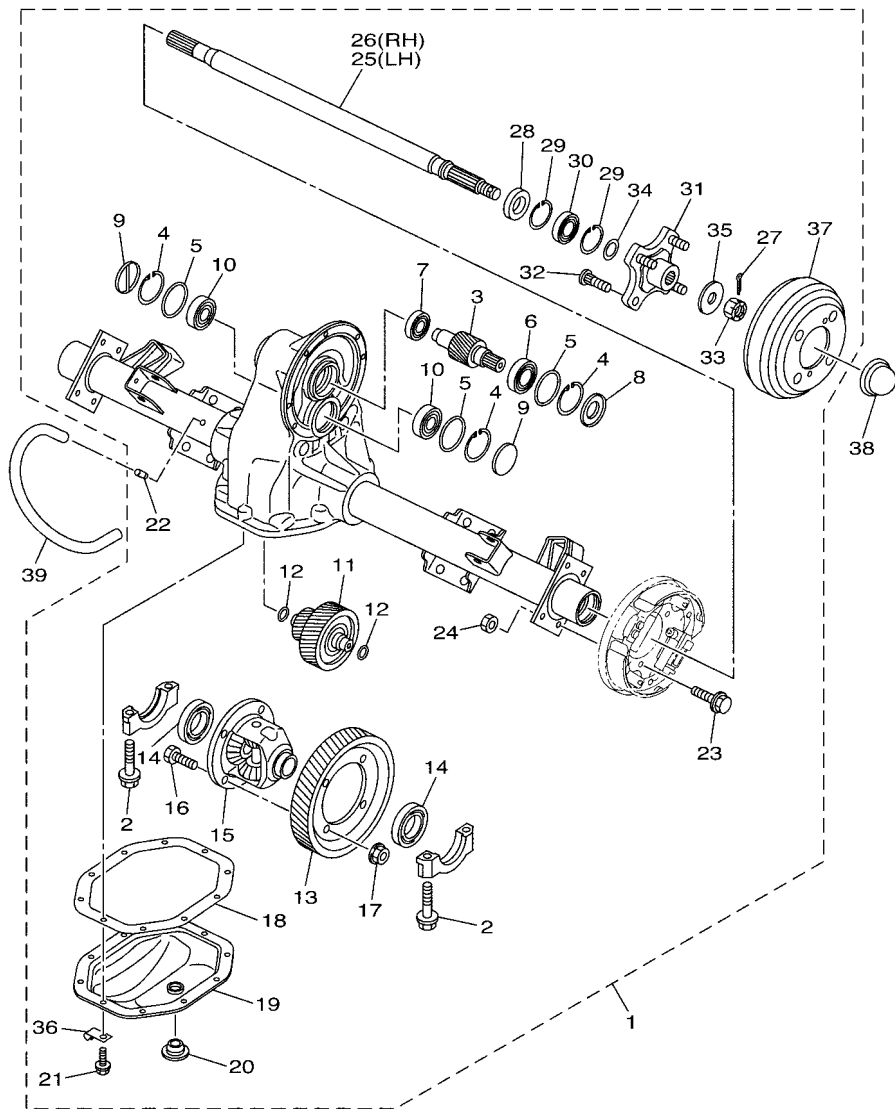

REF. NO.	PART NO.	DESCRIPTION	J/H				REMARKS
28	93101-24822	.OIL SEAL	2				
29	93420-44805	.CIRCLIP	4				
30	93306-00440	.BEARING	2				
31	JW8-G6514-00	.HUB, REAR AXLE	2				
32	JW8-G4178-00	.BOLT, STUD	8				
33	JW8-G5244-00	.NUT	2				
34	JW8-G2535-00	.WASHER, THRUST	2				
35	JW8-G2536-00	.WASHER, THRUST 2	2				
36	JW8-G2756-00	.STAY, CLAMP	1				
37	JW8-G6521-00	.DRUM	2				
38	JW8-F5118-00	COVER, HUB DUST	2				
39	JW8-G2541-00	PIPE 1	1				



J0C1110-S080

FIG. 10 WINDSHIELD

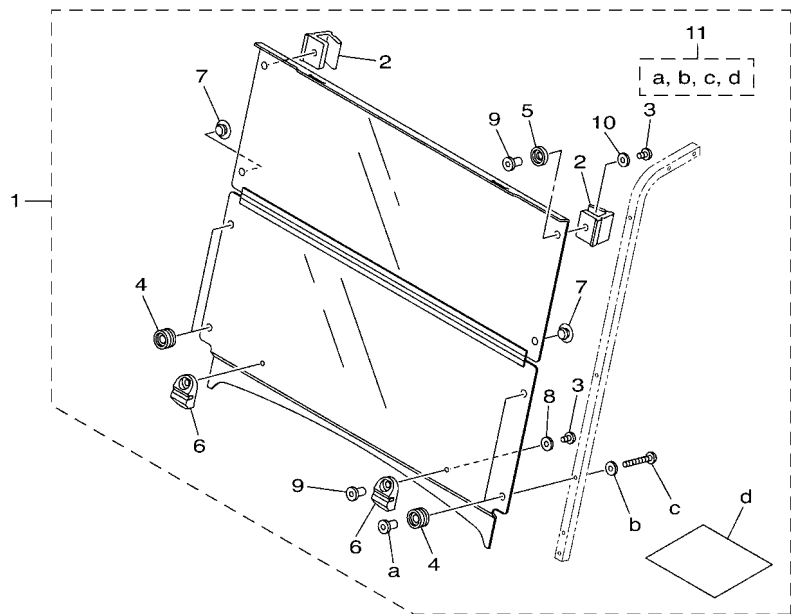

REF. NO.	PART NO.	DESCRIPTION	JTH				REMARKS
1	J0B-K7200-21	WINDSHIELD ASSY	1				
2	J0B-K7173-20	.LEVER, LATCH 1	2				
3	J0B-K7258-00	.SCREW, 2	4				
4	J0B-K7237-00	.GROMMET	4				
5	J0B-K7247-00	.GROMMET, W/S 2	2				
6	J0B-K7257-00	.GROMMET, W/S 3	2				
7	J0B-K7238-00	.DAMPER	2				
8	J0B-K7218-00	.WASHER 1	2				
9	J0B-K7217-00	.NUT, WIND SHIELD	4				
10	J0B-K7219-00	.WASHER 2	2				
11	J0B-K7240-20	.WIND SHIELD HARDWARE KIT 1	1				



J1G1400-T100

FIG. 11 BUMPER

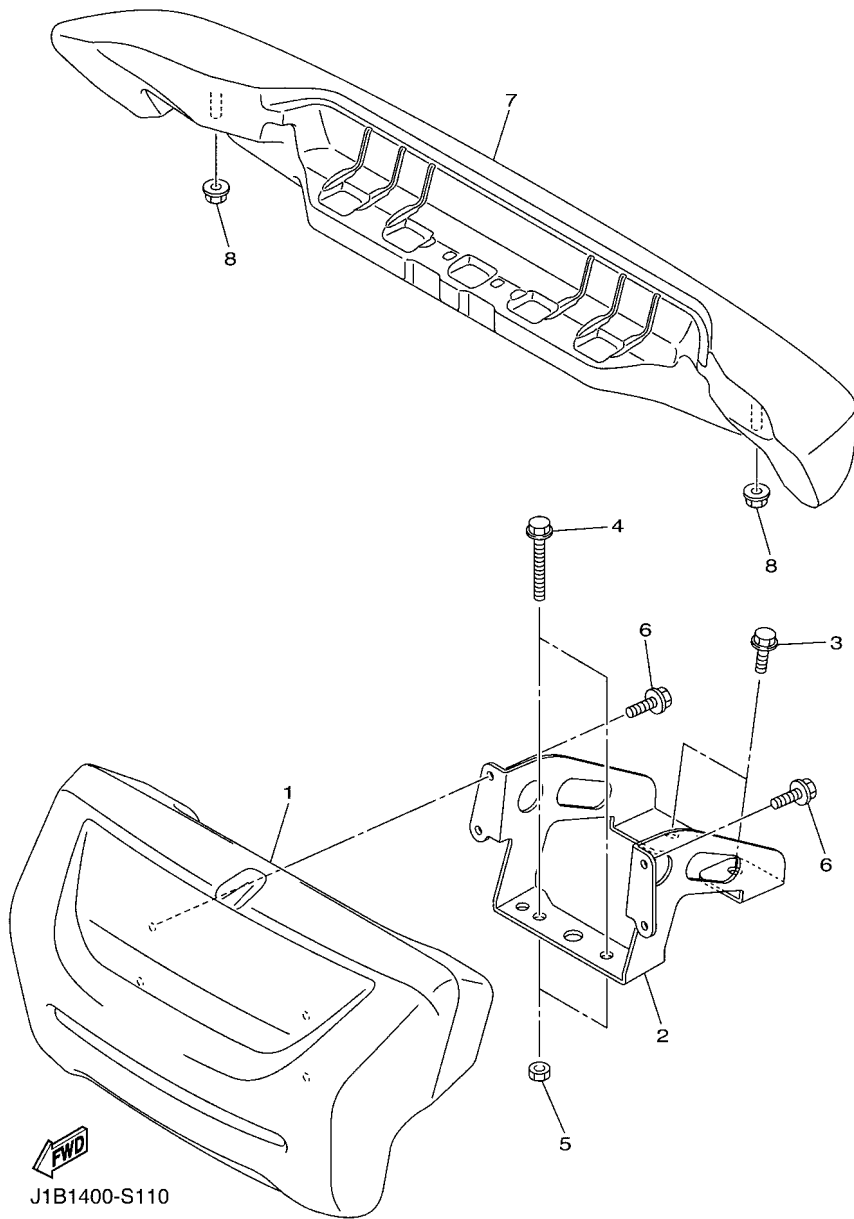

REF. NO.	PART NO.	DESCRIPTION	J1H1				REMARKS
1	J0B-K7510-01	FRONT BUMPER COMP.	1				
2	J1B-K8164-00	STAY, FRONT BUMPER (L.H)	1				
3	95812-08016	BOLT, FLANGE	2				
4	95D32-08050	BOLT, FLANGE DEEP RECESS	2				
5	95302-08700	NUT, HEXAGON	2				
6	95822-06012	BOLT, FLANGE	4				
7	J0B-K7540-00	REAR BUMPER COMP.	1				
8	95602-10200	NUT, S/L FLANGE	2				

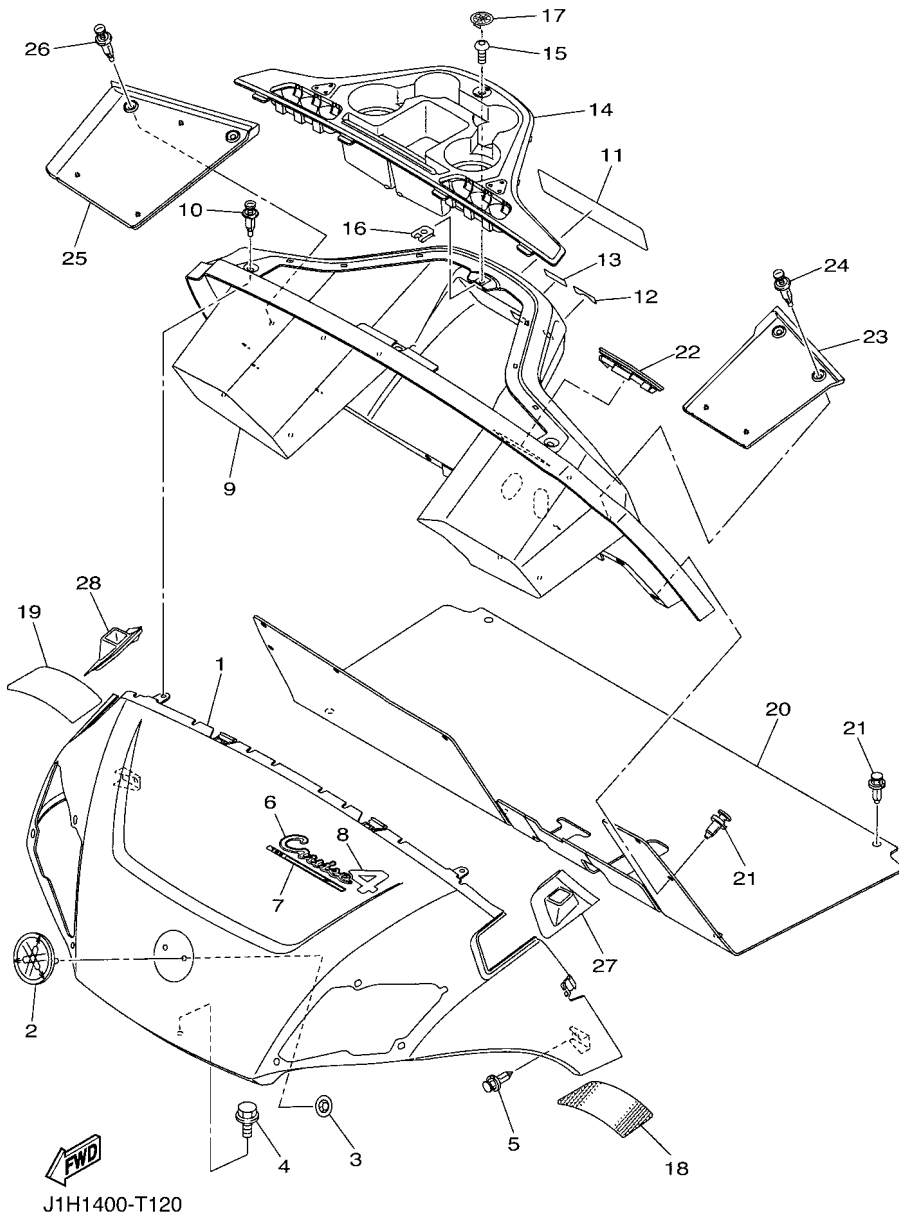
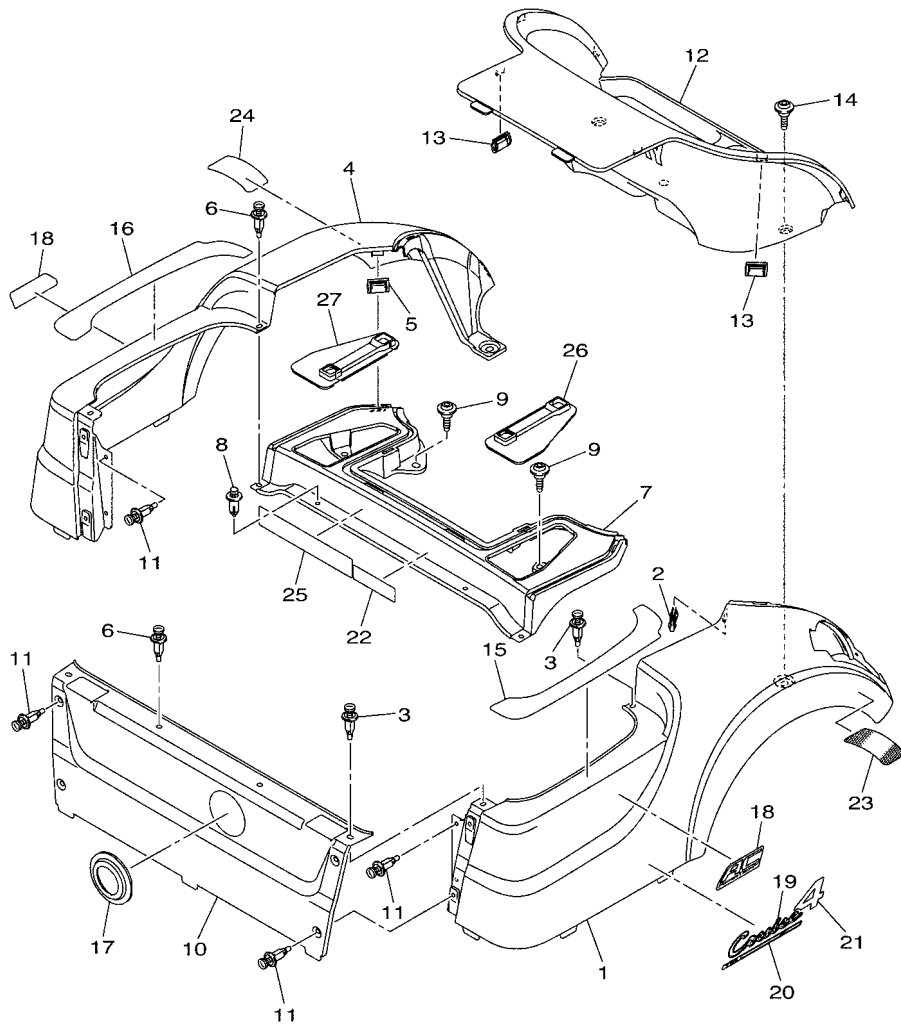

FIG. 12 BODY

REF. NO.	PART NO.	DESCRIPTION	J1H				REMARKS
1	J0D-K8115-A0	COWL, FRONT	1				
2	J1B-F4161-00	EMBLEM 1	1				
3	JU0-K7573-00	NUT, SPECIAL	2				
4	95812-06012	BOLT, FLANGE	1				
5	90269-06804	RIVET	2				
6	J1A-K81A1-00	EMBLEM 1	1				
7	J1B-K81B1-00	GRAPHIC 1	1				
8	J1F-K81A2-00	EMBLEM 2	1				
9	J0E-K8114-01	PANEL, FRONT	1				
10	90269-07805	RIVET	3				
11	J1B-K7768-00	LABEL, WARNING 8	1				
12	J1D-K8282-00	PLATE, SWITCH PANEL	1				
13	J1B-K7741-00	INDICATOR 1	1				
14	J0B-K835E-00	HOLDER, BEVERAGE	1				
15	90111-05805	BOLT,HEX. SOCKET BUTTON	1				
16	90183-05008	NUT, SPRING	1				
17	J1B-H2370-00	PLUG CAP ASSY	1				
18	J0D-H333B-00	REFLECTOR 1	1				
19	J0D-H334B-00	REFLECTOR, 2	1				
20	J0D-K8233-00	MAT, MAIN FLOOR 3	1				
21	90269-09003	RIVET	12				
22	J0B-K8273-10	COVER, HOLE	1				
23	J1B-K8243-00	MAT, REAR BODY SIDE (LH)	1				
24	90269-07805	RIVET	2				
25	J1B-K8244-00	MAT, REAR BODY SIDE (RH)	1				
26	90269-07805	RIVET	2				
27	J1B-K832F-00	GROMMET, ROOF SUPPORT 1	1				



J1H1400-T130

FIG. 13 BODY 2

REF. NO.	PART NO.	DESCRIPTION	J1H				REMARKS
1	J0D-K8111-A0	PANEL, BODY SHELL	1				
2	J0B-F3447-00	CLIP	1				
3	90269-07805	RIVET	3				
4	J0D-K8112-A0	PANEL, BODY SHELL	1				
5	J0B-F3447-00	CLIP	1				
6	90269-07805	RIVET	3				
7	J0B-K819H-00	SHELL, REAR BODY	1				
8	JW7-K7329-00	RIVET	2				
9	J0B-F1738-00	BOLT	4				
10	J1B-K8141-00	PANEL, INTERMEDIATE BODY	1				
11	90269-07805	RIVET	8				
12	J0B-K8237-02	COVER, REAR FLOOR	1				FOR 2 BAGS
13	J0B-F3447-00	CLIP	4				
14	J0B-F1738-00	BOLT	2				
15	J0B-F2873-01	SEAL 1	1				
16	J0B-F2874-01	SEAL 2	1				
17	J0C-K827A-00	GUIDE 1	1				
18	J1C-F1781-00	EMBLEM 1	2				
19	J1A-K81A1-00	EMBLEM 1	2				
20	J1B-K81B1-00	GRAPHIC 1	2				
21	J1F-K81A2-00	EMBLEM 2	2				
22	J1A-K8298-00	PLATE, CAUTION 2	1				
23	J0D-H360G-00	REFLECTOR 3	1				
24	J0D-H360H-00	REFLECTOR 4	1				
25	J1A-K8297-00	PLATE, CAUTION 1	1				
26	J0B-K817H-00	TRIM, SIDE PANEL 1	1				
27	J0B-K817J-00	TRIM, SIDE PANEL 2	1				

FIG. 14 BODY 3

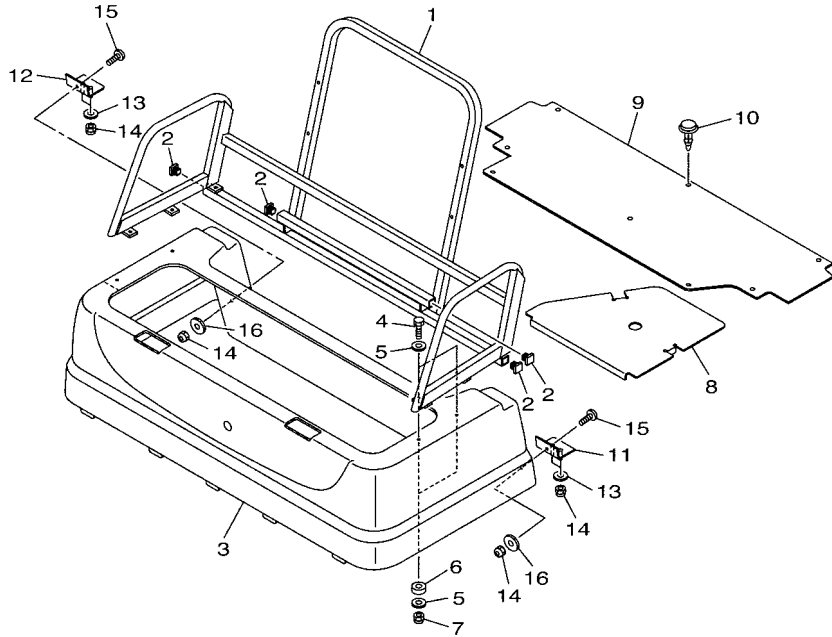

REF. NO.	PART NO.	DESCRIPTION	J1H				REMARKS
1	J1E-K8460-10	SEAT FRAME COMP.	1				
2	5FU-F111A-00	CAP, MAIN PIPE	4				
3	J2D-K8141-A0	PANEL, INTERMEDIATE BODY	1				
4	97027-06050	BOLT, HEXAGON	4				
5	92990-06200	WASHER, PLAIN	8				
6	J2B-K8328-00	SPACER 1	4				
7	95680-06100	NUT, U	4				
8	J1E-K811U-00	LID 2	1				
9	J2B-K8241-00	MAT, REAR FLOOR	1				
10	90269-09003	RIVET	8				
11	J1E-K8135-00	BRACKET 1	1				
12	J1E-K8136-00	BRACKET 2	1				
13	90201-06020	WASHER, PLATE	4				
14	95680-06100	NUT, U	6				
15	98580-06025	SCREW, PAN HEAD	2				
16	90201-06416	WASHER, PLATE	2				



J1F1400-S140

FIG. 15 BODY FITTING

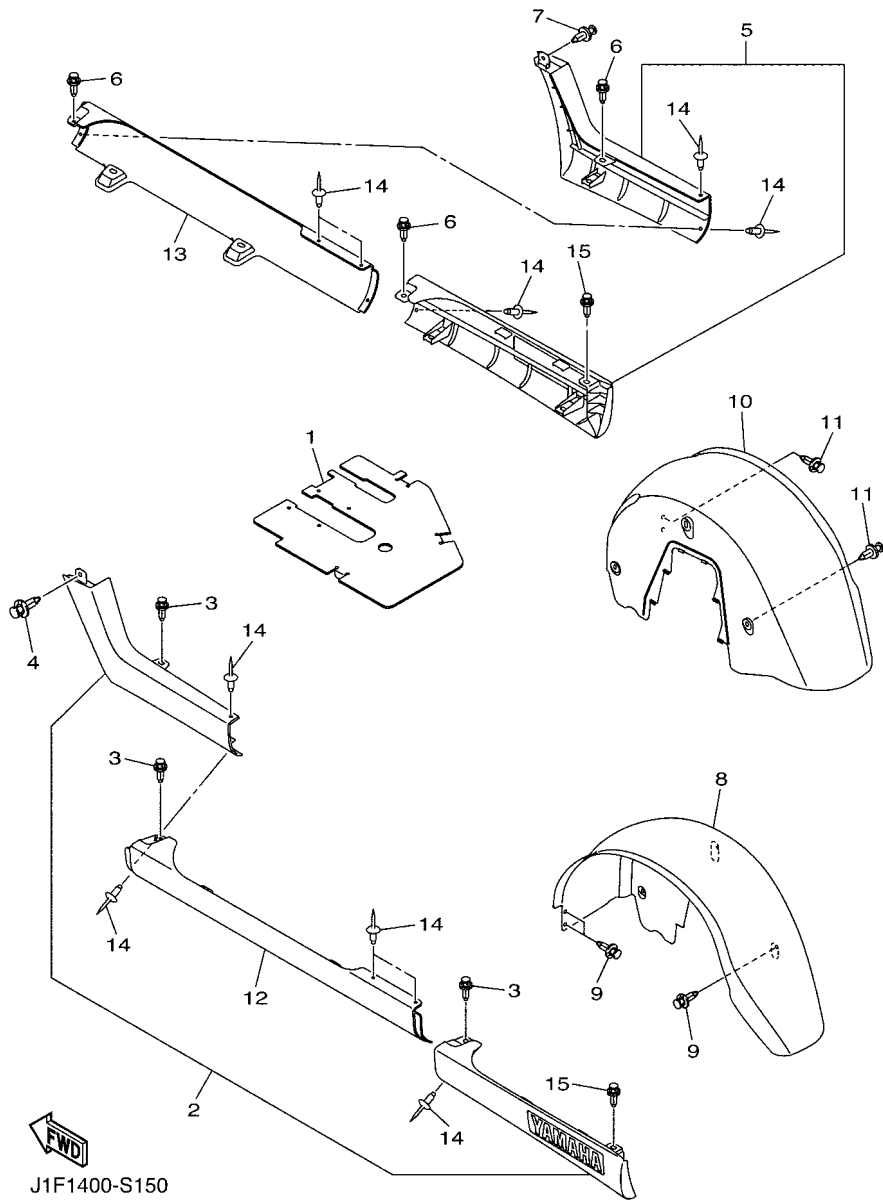

J1F1400-S150

REF. NO.	PART NO.	DESCRIPTION	J1H				REMARKS
1	J1B-K8271-00	SERVICE LID, PEDAL	1				
2	J1E-K818A-00	PROTECTOR, SIDE PLATE	1				
3	90269-09003	RIVET	3				
4	90269-06804	RIVET	1				
5	J1E-K818B-00	PROTECTOR, SIDE PLATE 2	1				
6	90269-09003	RIVET	3				
7	90269-06804	RIVET	1				
8	J0B-K8191-00	PANEL, REAR FENDER 1	1				
9	90269-06804	RIVET	5				
10	J0B-K8192-00	PANEL, REAR FENDER 2	1				
11	90269-06804	RIVET	5				
12	J1E-K8183-00	PLATE, SIDE SILL (L.H)	1				
13	J1E-K8184-00	PLATE, SIDE SILL (R.H)	1				
14	90267-48138	RIVET, BLIND	10				
15	90269-09003	RIVET	2				

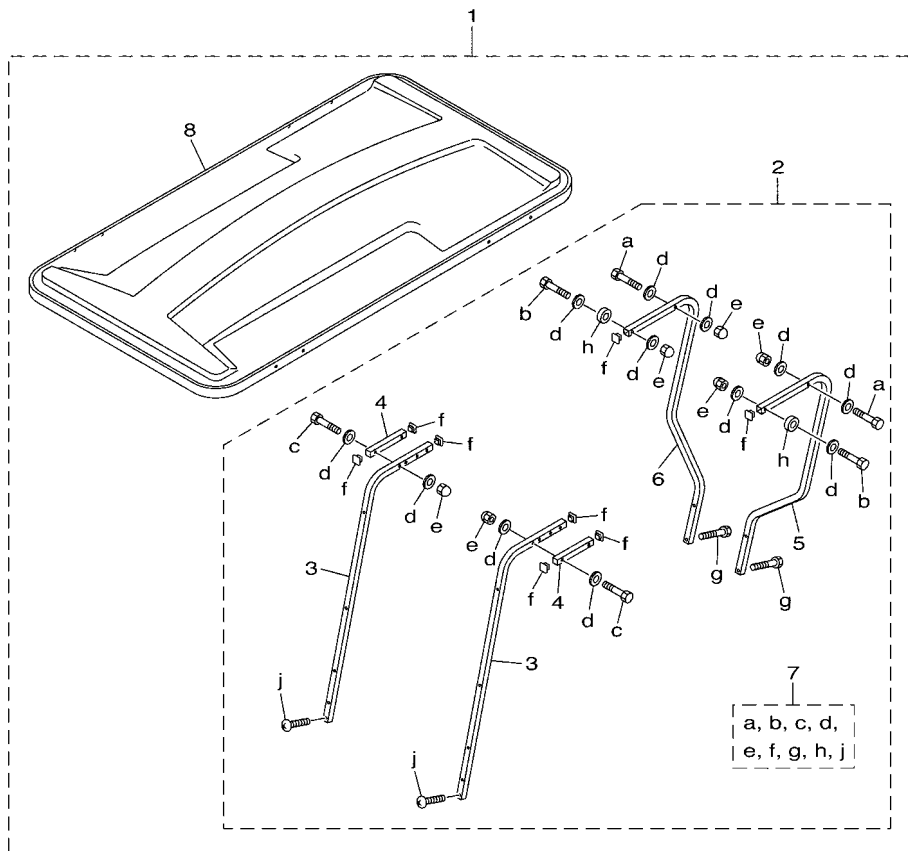

FIG. 16 SUN ROOF

REF. NO.	PART NO.	DESCRIPTION	J/H					REMARKS
1	J2B-K84A0-10	SUN TOP KIT	1					
2	J2B-K84A2-00	.HARDWARE KIT, SUN TOP	1					
3	J2B-K8312-00	..SUPPORT, SUN ROOF 1	2					
4	JP0-K8328-00	..SPACER 1	2					
5	J2B-K8313-00	..SUPPORT, SUN ROOF 2	1					
6	J2B-K831A-00	..SUPPORT, ROOF 3	1					
7	J2B-K84B2-00	..HARDWARE KIT, SUN TOP COVER	1					
8	JD1-K8314-10	..COVER, SUN ROOF	1					



J1F1400-S160

FIG. 17 CARRIER

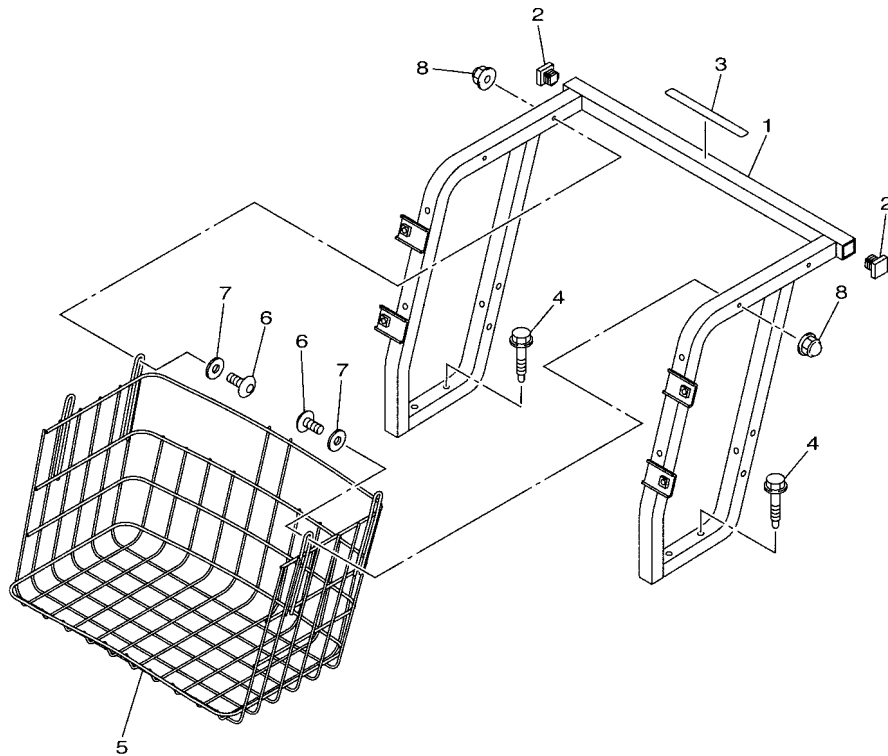

REF. NO.	PART NO.	DESCRIPTION	J1H				REMARKS
1	J1E-K8423-00	SUPPORT, SEAT BACK	1				
2	5FU-F111A-00	CAP, MAIN PIPE	2				
3	J1E-K7766-00	LABEL, WARNING 6	1				
4	90109-08178	BOLT	4				
5	JW1-K8340-00	LUGGAGE RACK ASSY., REAR	1				
6	92017-06040	BOLT, BUTTON HEAD	4				
7	90201-06020	WASHER, PLATE	4				
8	90176-06008	NUT, CROWN	4				



J1E1400-S170

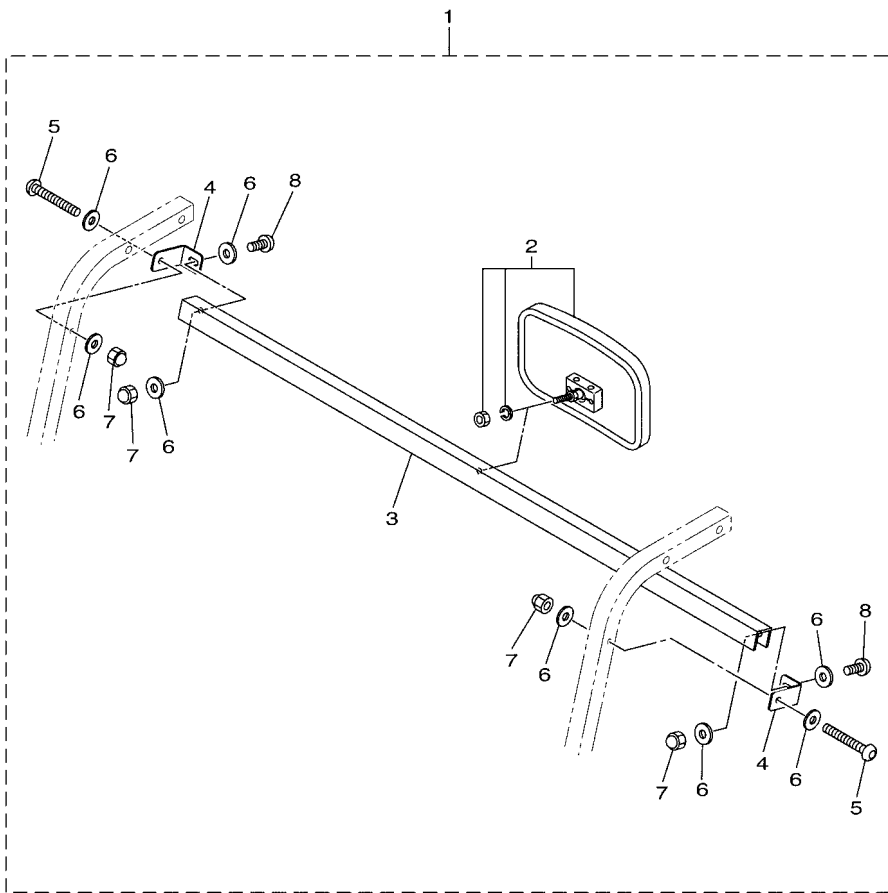

FIG. 18 REAR VIEW MIRROR

REF. NO.	PART NO.	DESCRIPTION	JTH				REMARKS
1	JC0-F6280-10	REAR VIEW MIRROR ASSY (LEFT)	1				
2	JC0-F6291-10	.MIRROR	1				
3	JC0-F831W-20	.STAY, MIRROR 1	1				
4	JC0-F834N-20	.BRACKET, MIRROR 1	2				
5	JW1-K7387-20	.SCREW	2				
6	JC0-K7178-00	.WASHER 1	8				
7	JW1-K7217-10	.NUT, WIND SHIELD	4				
8	JC0-K7212-10	.BOLT, WIND SHIELD	2				



JC06110-N280

FIG. 19 SEAT

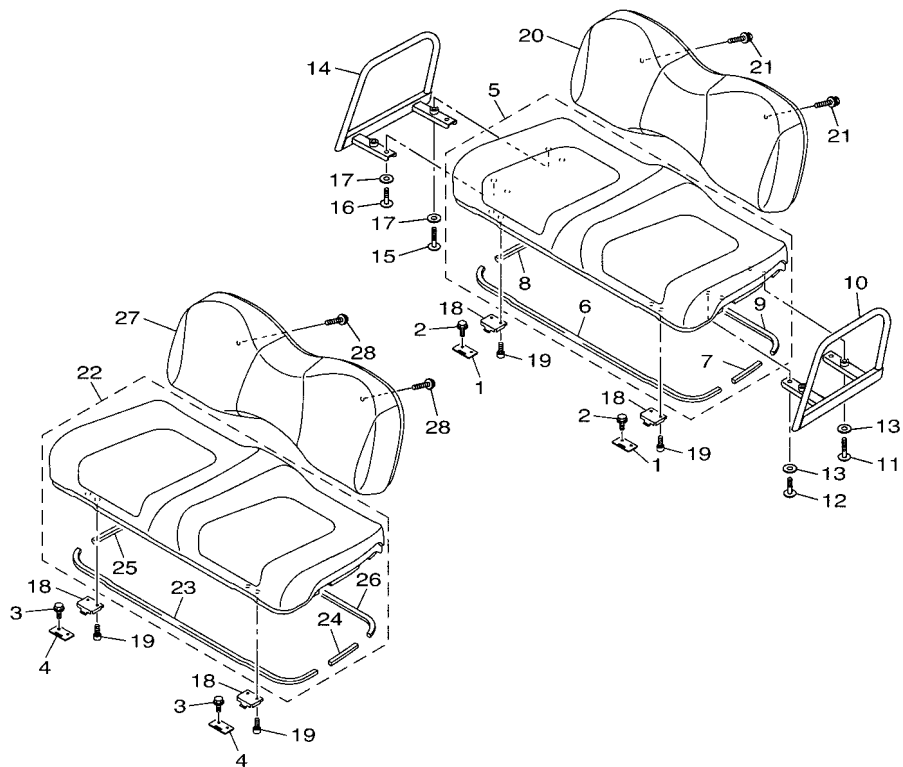

J1F1400-S180

REF. NO.	PART NO.	DESCRIPTION	J1H				REMARKS
1	J1A-K8427-00	HINGE, SEAT 2	2				
2	95802-06040	BOLT, FLANGE	4				
3	95802-06040	BOLT, FLANGE	4				
4	J1A-K8427-00	HINGE, SEAT 2	2				
5	J0A-K8401-00	SEAT SUB-ASSY,CUSHION	1				
6	J0B-K8245-00	.SEAL 1	1				
7	J0B-K8246-00	.SEAL 2	1				
8	J0B-K8247-00	.SEAL 3	1				
9	J0B-K8248-00	.SEAL 4	1				
10	J1E-K8361-00	ARM REST 1	1				
11	92012-06030	BOLT, BUTTON HEAD	2				
12	92012-06020	BOLT, BUTTON HEAD	2				
13	90201-06020	WASHER, PLATE	8				
14	J1E-K8362-00	ARM REST 2	1				
15	92012-06030	BOLT, BUTTON HEAD	2				
16	92012-06020	BOLT, BUTTON HEAD	2				
17	90201-06020	WASHER, PLATE	8				
18	J1B-K8426-00	HINGE, SEAT 1	4				
19	90110-06125	BOLT, HEXAGON SOCKET HEAD	8				
20	JW1-K8402-10	SEAT SUB ASSY, BACK	1				
21	97580-06540	BOLT, WITH WASHER	4				
22	J0A-K8401-00	SEAT SUB-ASSY,CUSHION	1				
23	J0B-K8245-00	.SEAL 1	1				
24	J0B-K8246-00	.SEAL 2	1				
25	J0B-K8247-00	.SEAL 3	1				
26	J0B-K8248-00	.SEAL 4	1				
27	JW1-K8402-10	SEAT SUB ASSY, BACK	1				

FIG. 19 SEAT

REF. NO.	PART NO.	DESCRIPTION	J1H	REMARKS
28	92017-06040	BOLT, BUTTON HEAD	4	
<hr/>				
<hr/>				
<hr/>				
<hr/>				
<hr/>				
<hr/>				
<hr/>				
<hr/>				
<hr/>				
<hr/>				

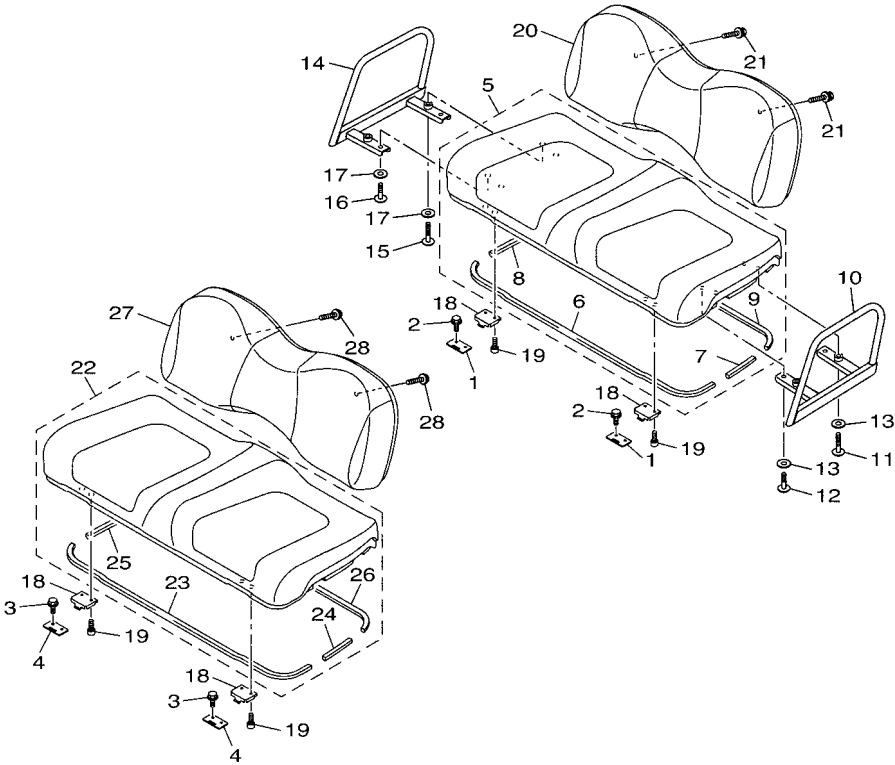

J1F1400-S180

FIG. 20 ELECTRIC MOTOR

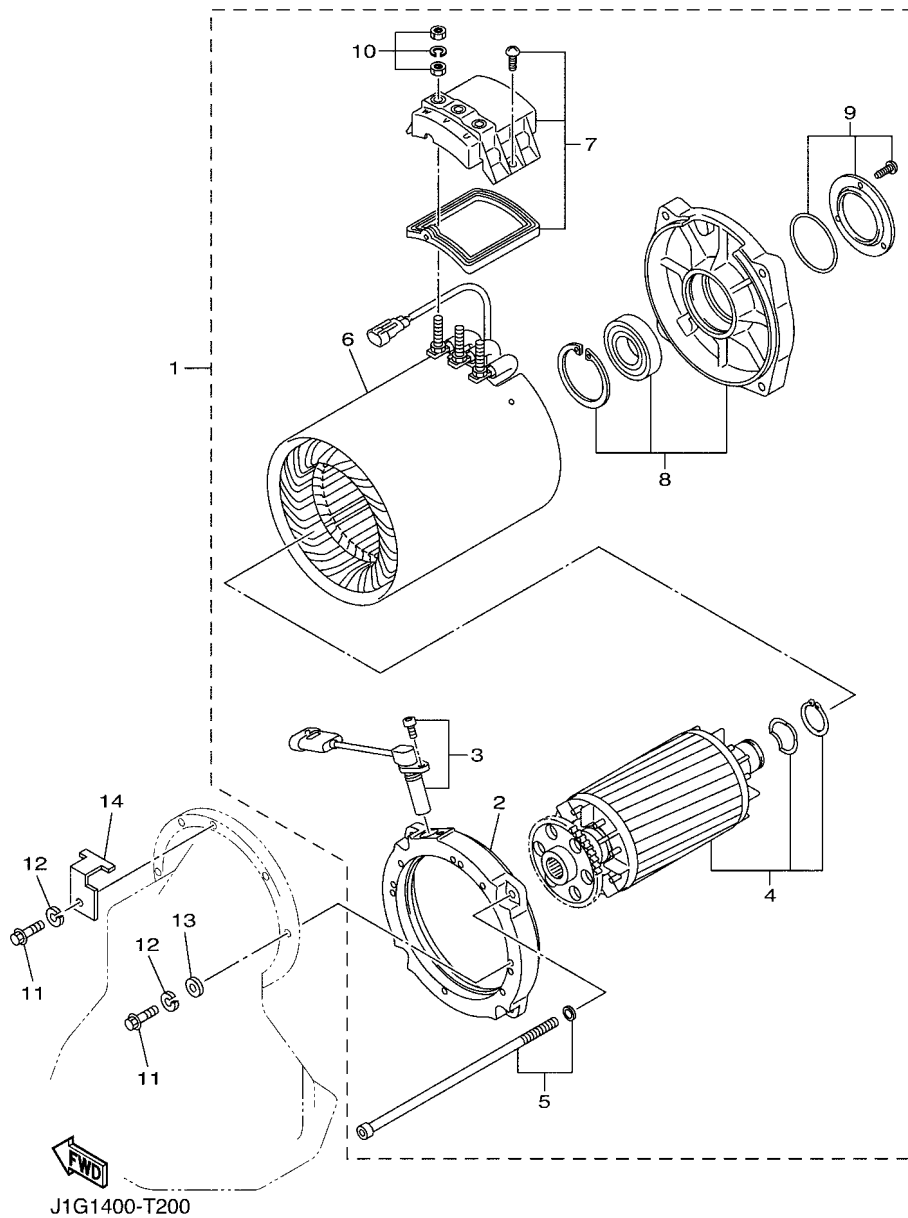

REF. NO.	PART NO.	DESCRIPTION	J1H1				REMARKS
1	JW3-H1890-10	MOTOR ASSY	1				
2	JW3-H183J-00	.BRACKET, FRONT	1				
3	JW3-H3756-00	.SENSOR, UNIT	1				
4	JW3-H1155-00	.ARMATURE	1				
5	JW3-H2379-00	.SCREW, UNIT	1				
6	JW3-H1117-10	.STATOR	1				
7	JW3-H165G-00	.PLTE, TERMINAL	1				
8	JW3-H182J-00	.BRACKET COMPLETE	1				
9	JW3-H1869-00	.COVER, DUST	1				
10	JW3-H182V-00	.NUT & WASHER KIT	1				
11	95812-06025	BOLT, FLANGE	3				
12	92990-06100	WASHER, SPRING	3				
13	90201-068E2	WASHER, PLATE	2				
14	JU2-H218E-01	RELIEF, STRAIN 1	1				

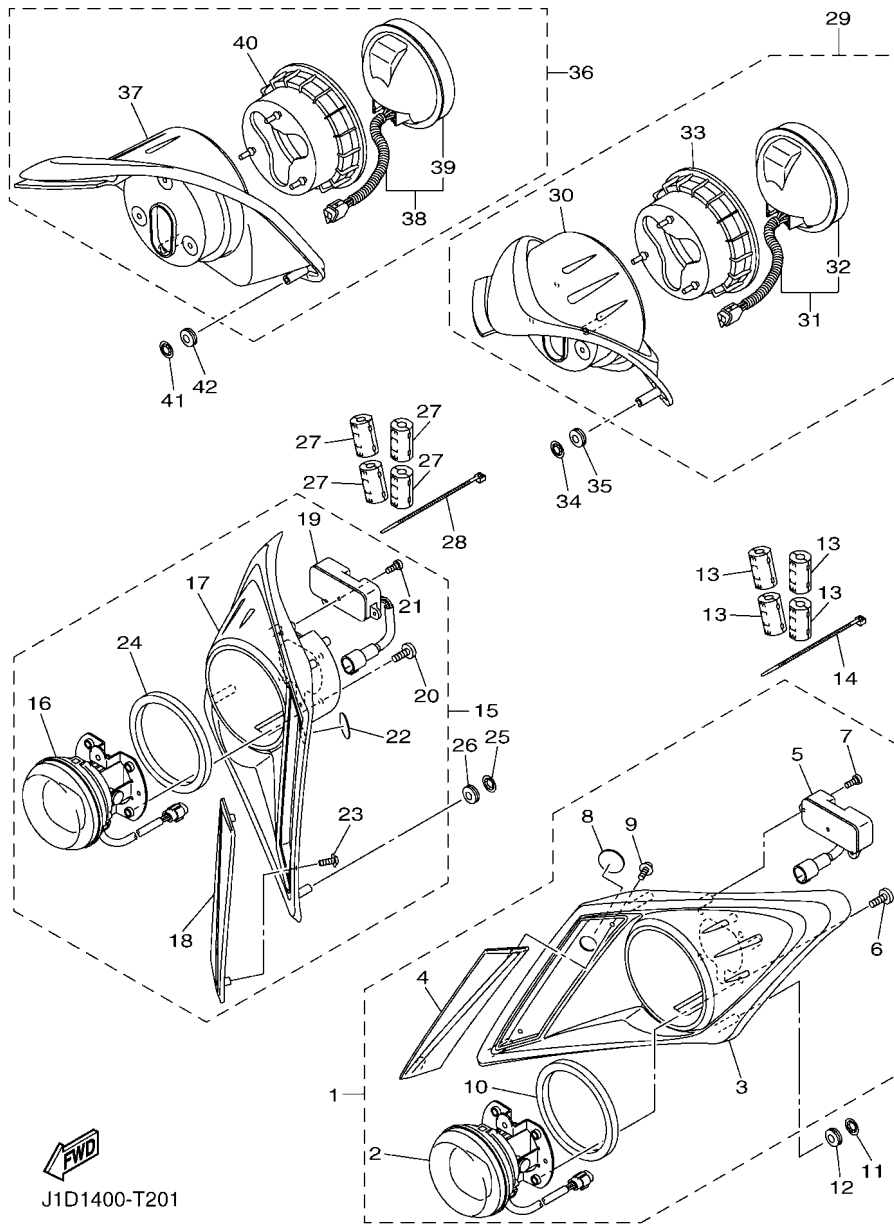
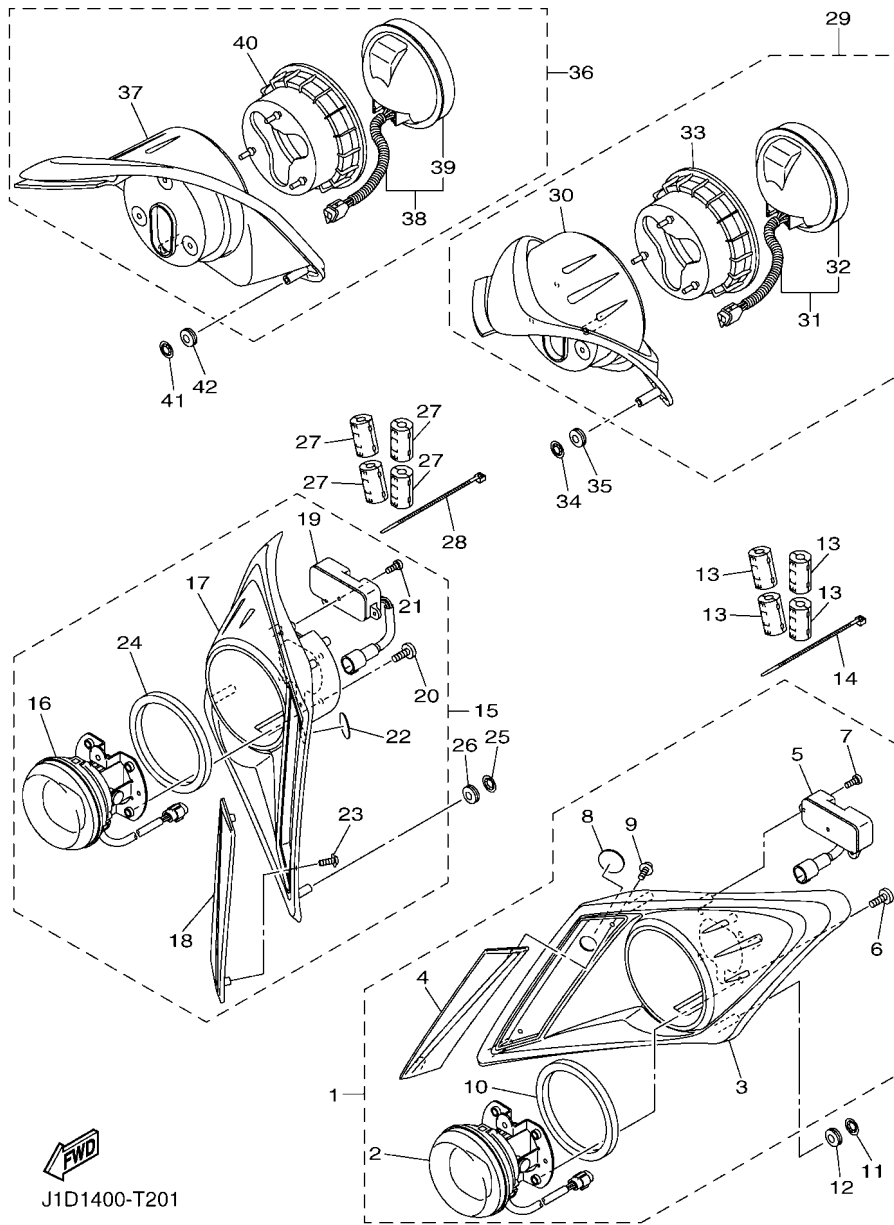

FIG. 21 HEAD & TAIL LIGHT

REF. NO.	PART NO.	DESCRIPTION	J/H				REMARKS
1	J0D-H4110-01	HEADLIGHT UNIT ASSY	1				
2	J0D-H4300-00	.HEADLIGHT ASSY	1				
3	J0D-H411T-00	.HOLDER, 1	1				
4	J0D-H4385-00	.CAP,1	1				
5	J0D-H5490-01	.LIGHT CONTROL UNIT	1				
6	J0D-H4526-00	.SCREW	4				
7	J0D-H4726-00	.SCREW	3				
8	J0D-H3547-00	.COVER, SOCKET	1				
9	J0D-H4524-00	.SCREW, LENS FITTING	2				
10	J0D-H4195-00	.RING, RETAINING	1				
11	90183-08800	NUT, SPRING	3				
12	90480-13016	GROMMET	3				
13	J1D-HA901-00	CORE 1	4				
14	90464-32804	CLAMP	1				
15	J0D-H4170-01	HEAD LIGHT UNIT ASSY	1				
16	J0D-H4300-00	.HEADLIGHT ASSY	1				
17	J0D-H411U-00	.HOLDER, 2	1				
18	J0D-H4386-00	.CAP,2	1				
19	J0D-H5490-01	.LIGHT CONTROL UNIT	1				
20	J0D-H4526-00	.SCREW	4				
21	J0D-H4726-00	.SCREW	3				
22	J0D-H3547-00	.COVER, SOCKET	1				
23	J0D-H4524-00	.SCREW, LENS FITTING	2				
24	J0D-H4195-00	.RING, RETAINING	1				
25	90183-08800	NUT, SPRING	3				
26	90480-13016	GROMMET	3				
27	J1D-HA901-00	CORE 1	4				



J1D1400-T201

FIG. 21 HEAD & TAIL LIGHT

REF. NO.	PART NO.	DESCRIPTION	J1H1				REMARKS
28	90464-32804	CLAMP	1				
29	J0D-H4710-00	TAILLIGHT UNIT ASSY	1				
30	J0D-H431U-00	.HOLDER	1				
31	J0D-H4700-00	.TAILLIGHT ASSY	1				
32	JC0-H4514-00	.BULB	1				(12V-7W/27W)
33	J0D-H4718-00	.GROMMET	1				
34	90183-08800	NUT, SPRING	2				
35	90480-13016	GROMMET	2				
36	J0D-H4730-00	TAILLIGHT UNIT ASSY	1				
37	J0D-H4387-00	.HOLDER	1				
38	J0D-H4700-00	.TAILLIGHT ASSY	1				
39	JC0-H4514-00	.BULB	1				(12V-7W/27W)
40	J0D-H4718-00	.GROMMET	1				
41	90183-08800	NUT, SPRING	2				
42	90480-13016	GROMMET	2				

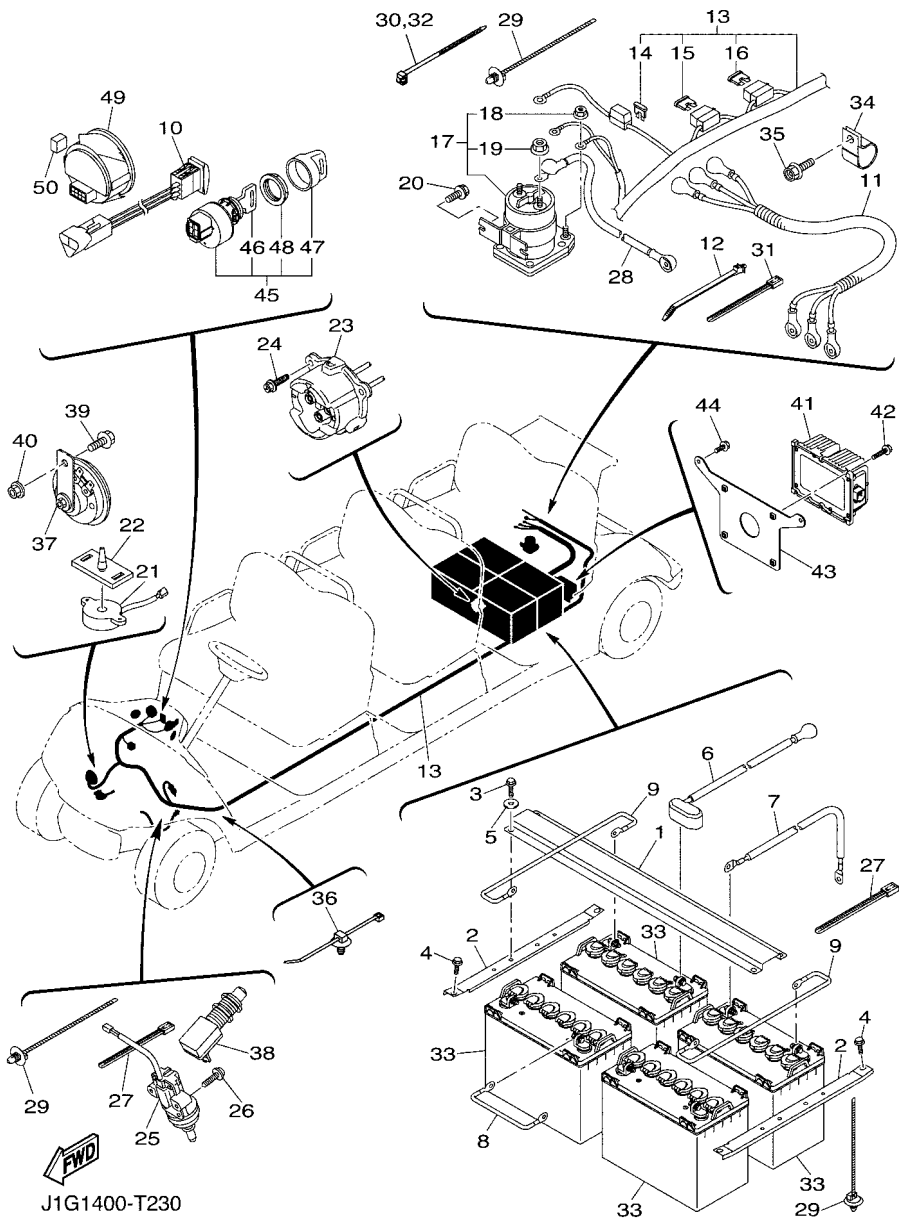

FIG. 23 ELECTRICAL 1

REF. NO.	PART NO.	DESCRIPTION	J/H				REMARKS
1	J1A-H2136-01	PLATE, BATTERY FITTING	1				
2	J1A-H213E-01	PLATE, BETTERY FITTING	2				
3	97027-08020	BOLT, HEXAGON	4				
4	95822-08016	BOLT, FLANGE	4				
5	92907-08200	WASHER	4				
6	J1D-H2115-00	WIRE, PLUS LEAD	1				
7	J1D-H2116-00	WIRE, MINUS LEAD	1				
8	J1B-H2127-00	WIRE, LEAD 2	1				
9	J1A-H2149-00	WIRE, LEAD 3	2				
10	JU2-H2917-00	SWITCH	1				
11	J1D-H1441-01	LEAD WIRE ASSY	1				
12	90464-20005	CLAMP	3				
13	J1H-H2590-01	WIRE HARNESS ASSY	1				
14	J0E-H2151-00	.FUSE (10A)	1				
15	JR1-H2151-00	.FUSE (3A)	1				
16	J0E-H2151-10	.FUSE (1A)	1				
17	JU6-H1950-00	RELAY ASSY	1				
18	90179-05807	.NUT	2				
19	90179-08824	.NUT	2				
20	95822-06012	BOLT, FLANGE	2				
21	JR1-H3383-02	BUZZER	1				
22	JN6-H3386-01	STAY, BUZZER	1				
23	JW9-H6181-00	RECEPTACLE	1				
24	97502-05516	BOLT, WITH WASHER	3				
25	JF7-82817-22	SWITCH	1				
26	97602-05225	SCREW, PAN HEAD WITH WASHER	2				
27	90464-32804	CLAMP	4				

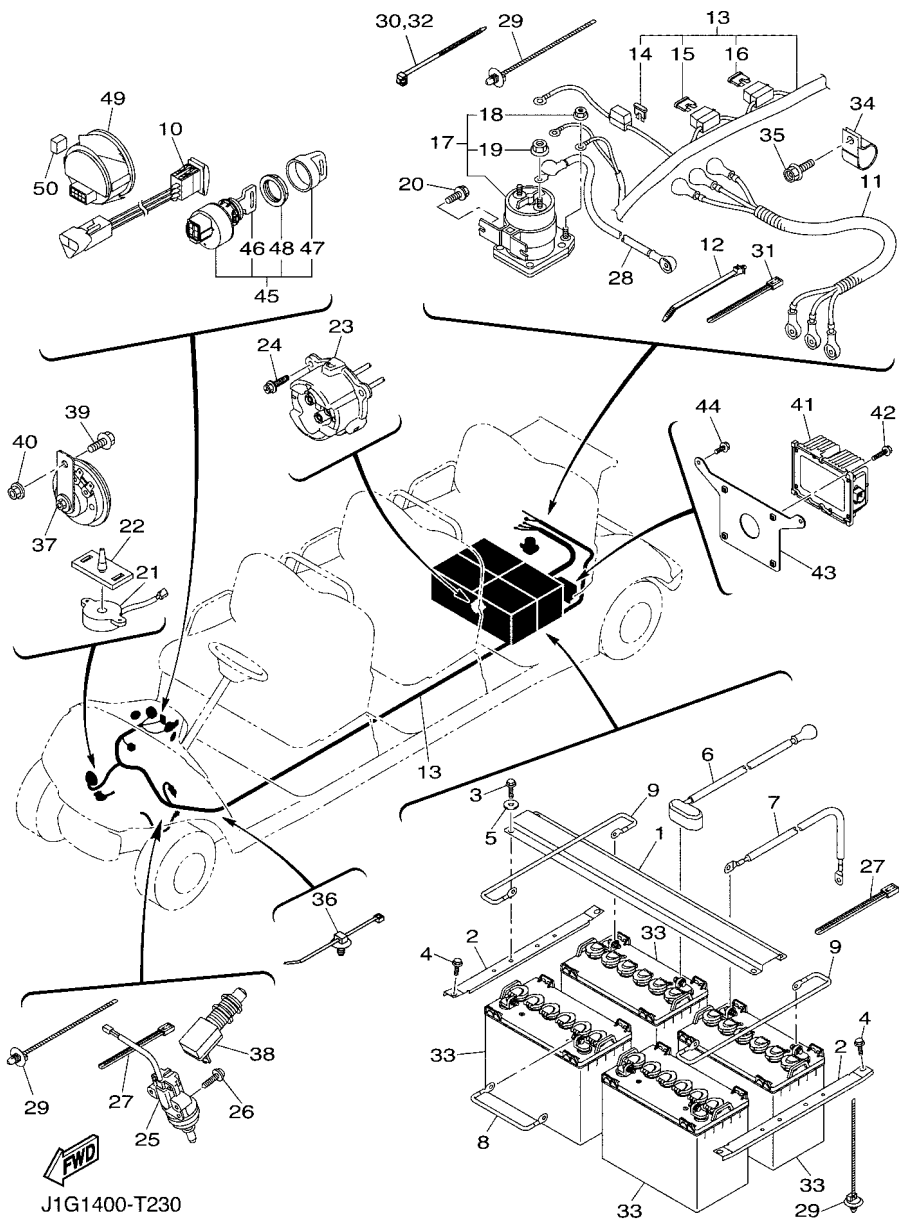

FIG. 23 ELECTRICAL 1

REF. NO.	PART NO.	DESCRIPTION	JTH	REMARKS
28	J1D-H6527-00	WIRE 7	1	
29	90464-20005	CLAMP	11	
30	90464-70803	CLAMP	2	
31	90464-32804	CLAMP	1	
32	90464-70803	CLAMP	1	
33	*	BATTERY (GS BV150Z)	4	LM
34	90461-14108	CLAMP	1	
35	95822-08016	BOLT, FLANGE	1	
36	1NS-F1338-00	CLAMP	1	
37	5YP-H3371-10	HORN	1	
38	JR6-H270X-00	SWITCH	1	
39	95822-06016	BOLT, FLANGE	1	
40	95702-06500	NUT, FLANGE	1	
41	J0E-81910-00	VOLTAGE REGULATOR ASSY	1	
42	97502-05516	BOLT, WITH WASHER	4	
43	J1D-F7876-00	BRACKET, SWITCH	1	
44	95822-06016	BOLT, FLANGE	2	
45	JW6-H2510-00	MAIN SWITCH ASSY	1	
46	JU6-H2511-10	.KEY, MAIN SWITCH	2	
47	5UG-H2579-00	.CAP, KEY	1	
48	JU6-H2569-00	.NUT, MAIN SWITCH	1	
49	JC1-H351B-01	GAUGE, BATTERY	1	
50	J1B-K821A-00	PAD, BODY MOUNTING1	1	

NUMERICAL INDEX

PART NO.	REF. NO.	PART NO.	REF. NO.	PART NO.	REF. NO.	PART NO.	REF. NO.	PART NO.	REF. NO.	PART NO.	REF. NO.
JX4-22123-00	1 - 2	J1B-F255G-00	2 - 2	JW8-F7113-00	6 - 11	JC0-F834N-20	18 - 4	JW3-H2379-00	20 - 5	JW9-H5885-00	6 - 52
J1A-23400-00	4 - 10	J1E-F255G-00	2 - 21	JW8-F7117-00	6 - 6	JW8-F8363-00	6 - 7	JW6-H2510-00	23 - 45	JW9-H6181-00	23 - 23
2NL-23448-00	3 - 9	J1B-F258E-00	2 - 6	JW8-F7118-00	6 - 41	JW8-G2535-00	8 - 34	JU6-H2511-10	23 - 46	J1D-H6527-00	23 - 28
J1A-23489-00	4 - 20	J0B-F2873-01	13 - 15	JW8-F7119-00	6 - 28	JW8-G2536-00	8 - 35	JU6-H2569-00	23 - 48	J1D-HA901-00	21 - 13
2NL-23517-00	3 - 11	J0B-F2874-01	13 - 16	JW8-F7121-00	6 - 13	JW8-G2541-00	8 - 39	5UG-H2579-00	23 - 47		21 - 27
2HR-23526-00	3 - 3	JW8-F3183-00	6 - 16	JW9-F7200-21	6 - 2	JW8-G2756-00	8 - 36	J1H-H2590-01	23 - 13	J0B-K7173-20	10 - 2
J1A-23527-00	4 - 21	J0C-F3350-00	3 - 14	JW8-F7213-20	6 - 34	JH7-G3396-01	8 - 9	JR6-H270X-00	23 - 38	JC0-K7178-00	18 - 6
JX4-23812-00	4 - 13	J0C-F3390-00	3 - 19	JW8-F7217-00	6 - 32	JW8-G4178-00	8 - 32	JW2-H2727-00	22 - 2	J0B-K7200-21	10 - 1
J1A-23822-00	4 - 29	J0B-F3447-00	13 - 2	JW8-F7218-00	6 - 10	JW8-G5244-00	8 - 33	JU2-H2917-00	23 - 10	JC0-K7212-10	18 - 8
J1A-23837-00	4 - 22		13 - 5	JW9-F7221-00	6 - 14	JW8-G5378-00	8 - 22	J0D-H333B-00	12 - 18	J0B-K7217-00	10 - 9
JR7-23844-00	4 - 19		13 - 13	JW9-F7228-00	6 - 23	JW9-G6136-00	8 - 8	J0D-H334B-00	12 - 19	JW1-K7217-10	18 - 7
JX4-2384N-00	4 - 12	JU0-F3511-10	3 - 4	JW9-F7231-10	6 - 18	J0C-G6300-01	7 - 1	5YP-H3371-10	23 - 37	J0B-K7218-00	10 - 8
JR7-23866-00	4 - 24	JW1-F3512-00	3 - 5	JW9-F7232-00	6 - 19		8 - 1	JR1-H3383-02	23 - 21	J0B-K7219-00	10 - 10
J1A-2387A-00	4 - 11	JU0-F3521-10	3 - 12	JW9-F7245-10	6 - 30	JW9-G6312-00	8 - 19	JN6-H3386-01	23 - 22	J0B-K7237-00	10 - 4
J1A-2387E-00	4 - 14	JU0-F3570-20	3 - 1	JW9-F7246-20	6 - 46	JW9-G631A-00	8 - 18	JC1-H351B-01	23 - 49	J0B-K7238-00	10 - 7
JR7-2387F-00	4 - 17	JW1-F3811-03	4 - 1	JW9-F7263-00	6 - 49	JW9-G6321-00	8 - 3	J0D-H3547-00	21 - 8	J0B-K7240-20	10 - 11
JR7-2387G-00	4 - 15	JU0-F3828-10	4 - 4	JW8-F7280-10	7 - 13	JW9-G6350-00	8 - 11		21 - 22	J0B-K7247-00	10 - 5
JR7-2387J-00	4 - 18	1P0-F3833-00	4 - 26	JW8-F7281-00	7 - 5	JW9-G6410-00	8 - 15	J0D-H360G-00	13 - 23	J0B-K7257-00	10 - 6
JR7-2387K-00	4 - 16	JN3-F3838-00	4 - 6		7 - 16	JW9-G6421-00	8 - 13	J0D-H360H-00	13 - 24	J0B-K7258-00	10 - 3
JR7-23894-00	4 - 25	J1A-F3841-00	4 - 27	JW8-F7286-00	7 - 10	JN3-G6432-00	8 - 20	JW3-H3756-00	20 - 3	JW7-K7329-00	13 - 8
JR7-2467K-00	4 - 23	JU0-F3857-11	4 - 3		7 - 21	JR1-G6511-00	8 - 25	J0D-H4110-01	21 - 1	JW1-K7387-20	18 - 5
J38-27204-00	7 - 15		4 - 5	JW8-F7290-10	7 - 2	JR1-G6512-00	8 - 26	J0D-H411T-00	21 - 3	J0B-K7510-01	11 - 1
J38-27205-00	7 - 4	J1B-F4161-00	12 - 2	JW8-F7316-01	6 - 31	JW8-G6514-00	8 - 31	J0D-H411U-00	21 - 17	J0B-K7540-00	11 - 7
J55-27260-00	7 - 9	JW8-F41B8-00	6 - 51	JW8-F7317-00	6 - 40	JW8-G6521-00	8 - 37	JU0-H4170-01	21 - 15	JU0-K7573-00	12 - 3
J55-27270-00	7 - 20	JW8-F4486-00	6 - 44	JW8-F7318-00	6 - 20	JW3-H1117-10	20 - 6	J0D-H4195-00	21 - 10	J1B-K7741-00	12 - 13
J10-27282-00	7 - 6		6 - 48	JW8-F7322-00	6 - 15	JW3-H1155-00	20 - 4		21 - 24	JW8-K7762-00	4 - 37
	7 - 17	JW9-F4648-20	6 - 50	J1E-F7411-00	2 - 14	J1D-H1441-01	23 - 11	J0D-H4300-00	21 - 2	J1E-K7766-00	17 - 3
J0E-81910-00	23 - 41	J1E-F5100-00	9 - 1	J1E-F7411-20	2 - 4	JW3-H165G-00	20 - 7		21 - 16	J1B-K7768-00	12 - 11
JF7-82817-22	23 - 25	JC1-F5103-00	3 - 21	JW8-F7416-00	6 - 8	JW3-H182J-00	20 - 8	J0D-H431U-00	21 - 30	J0D-K8111-A0	13 - 1
JC3-86510-10	22 - 1	JW8-F5118-00	8 - 38	JW8-F7426-01	6 - 17	JW3-H182V-00	20 - 10	J0D-H4385-00	21 - 4	J0D-K8112-A0	13 - 4
5FU-F111A-00	14 - 2	JN6-F5118-01	3 - 29	JW8-F7434-00	6 - 39	JW3-H183J-00	20 - 2	J0D-H4386-00	21 - 18	J0E-K8114-01	12 - 9
	17 - 2	JW8-F5415-00	6 - 25	JW8-F7435-00	6 - 56	JW3-H1869-00	20 - 9	J0D-H4387-00	21 - 37	J0D-K8115-A0	12 - 1
1NS-F1338-00	23 - 36	JW9-F5666-00	6 - 12	JW8-F7438-00	6 - 38	JW3-H1890-10	20 - 1	JC0-H4514-00	21 - 32	J1E-K811U-00	14 - 8
J0B-F1738-00	2 - 5	JW9-F5671-00	6 - 5	JW9-F7445-31	6 - 33	JU6-H1950-00	23 - 17		21 - 39	J1E-K8135-00	14 - 11
	2 - 15	JW9-F5672-00	6 - 4	J1E-F7452-00	2 - 20	J1A-H1962-00	24 - 3	J0D-H4524-00	21 - 9	J1E-K8136-00	14 - 12
	13 - 9	JW9-F5673-00	6 - 45	JW8-F7814-21	6 - 3	JW2-H2107-13	24 - 1		21 - 23	J1B-K8141-00	13 - 10
	13 - 14	JW8-F5681-10	5 - 5		6 - 43	J1D-H2115-00	23 - 6	J0D-H4526-00	21 - 6	J2D-K8141-A0	14 - 3
J1C-F1781-00	13 - 18	JN6-F5685-01	5 - 6	JW8-F7825-01	6 - 27	J1D-H2116-00	23 - 7		21 - 20	J1B-K8164-00	11 - 2
J1B-F2110-00	1 - 1	JW9-F5827-00	6 - 53	JW9-F7850-31	6 - 1	J1B-H2127-00	23 - 8	J0D-H4700-00	21 - 31	J1B-K816M-00	2 - 28
JN6-F2124-10	1 - 6	JW9-F5827-10	6 - 53	JW9-F7853-00	6 - 35	J1A-H2136-01	23 - 1		21 - 38	J0B-K817H-00	13 - 26
J1B-F2127-00	2 - 8	JC0-F6280-10	18 - 1	JW9-F7871-10	6 - 36	J1A-H213E-01	23 - 2	J0D-H4710-00	21 - 29	J0B-K817J-00	13 - 27
J1A-F2128-00	3 - 16	JC0-F6291-10	18 - 2	JW9-F7872-20	6 - 37	J1A-H2149-00	23 - 9	J0D-H4718-00	21 - 33	J1E-K8183-00	15 - 12
J1A-F217G-00	1 - 10	JW8-F6314-00	6 - 21	J1D-F7876-00	23 - 43	J0E-H2151-00	23 - 14		21 - 40	J1E-K8184-00	15 - 13
JW6-F2210-01	1 - 12	JW9-F632G-00	6 - 54	JW8-F815H-01	6 - 42	JR1-H2151-00	23 - 15	J0D-H4726-00	21 - 7	J1E-K818A-00	15 - 2
JW9-F2417-00	2 - 13	J1F-F6341-00	5 - 13	JW8-F8319-00	6 - 29	J0E-H2151-10	23 - 16		21 - 21	J1E-K818B-00	15 - 5
J1F-F2501-00	2 - 1	J1F-F6351-00	5 - 1	JC0-F831W-20	18 - 3	JU2-H218E-01	20 - 14	J0D-H4730-00	21 - 36	J0B-K8191-00	15 - 8
J1C-F252M-00	2 - 9	JW8-F639L-00	6 - 22	JW8-F8323-00	6 - 24	JR1-H235A-00	24 - 2	J0D-H5490-01	21 - 5	J0B-K8192-00	15 - 10
J1A-F2535-01	2 - 11	JW8-F639N-00	6 - 9	JW8-F8331-00	6 - 47	J1B-H2370-00	12 - 17		21 - 19	J0B-K819H-00	13 - 7

NUMERICAL INDEX

PART NO.	REF. NO.	PART NO.	REF. NO.	PART NO.	REF. NO.	PART NO.	REF. NO.	PART NO.	REF. NO.	PART NO.	REF. NO.
J1A-K81A1-00	12 - 6	J1A-K8427-00	19 - 4	90209-32271	3 - 27	91702-10026	5 - 2	95812-08020	4 - 2		
	13 - 19	J1E-K8460-10	14 - 1	90249-14129	5 - 9	92012-06020	19 - 12		6 - 57		
J1F-K81A2-00	12 - 8	J2B-K84A0-10	16 - 1	90267-48138	15 - 14		19 - 16	95812-08040	2 - 3		
	13 - 21	J2B-K84A2-00	16 - 2	90269-06804	12 - 5	92012-06030	19 - 11	95812-10016	1 - 5		
J1B-K81B1-00	12 - 7	J2B-K84B2-00	16 - 7		15 - 4		19 - 15	95812-10040	4 - 28		
	13 - 20	JN9-W2536-11	7 - 3		15 - 7	92017-06040	17 - 6	95812-10055	1 - 13		
J1B-K821A-00	2 - 27		7 - 14		15 - 9		19 - 28	95812-12065	1 - 7		
	23 - 50	90101-08855	8 - 23		15 - 11	92902-12200	4 - 8	95812-12080	3 - 17		
J0D-K8233-00	12 - 20	90101-08856	8 - 21	90269-07805	12 - 10	92907-08200	23 - 5	95822-06012	11 - 6		
J0B-K8237-02	13 - 12	90101-10854	8 - 16		12 - 24	92907-08600	22 - 4		23 - 20		
J2B-K8241-00	14 - 9	90105-10219	3 - 8		12 - 26	92990-06100	20 - 12	95822-06016	2 - 10		
J1B-K8243-00	12 - 23	90105-10267	3 - 13		13 - 3	92990-06200	2 - 19		23 - 39		
J1B-K8244-00	12 - 25		3 - 20		13 - 6		2 - 24		23 - 44		
J0B-K8245-00	19 - 6	90105-10373	3 - 6		13 - 11		14 - 5	95822-08016	2 - 7		
	19 - 23	90105-10840	8 - 2	90269-09003	12 - 21	93101-24822	8 - 28		2 - 12		
J0B-K8246-00	19 - 7	90105-12031	1 - 3		14 - 10	93102-30803	3 - 26		23 - 4		
	19 - 24	90109-08178	17 - 4		15 - 3	93210-148B9	8 - 12		23 - 35		
J0B-K8247-00	19 - 8	90110-06125	19 - 19		15 - 6	93210-478B8	8 - 5	95D02-06025	22 - 5		
	19 - 25	90111-05805	12 - 15		15 - 15	93306-00440	8 - 30	95D32-08030	2 - 29		
J0B-K8248-00	19 - 9	90114-12004	3 - 22	90381-17800	3 - 10	93306-005Y1	8 - 6	95D32-08050	11 - 4		
	19 - 26	90170-08841	8 - 24	90381-18001	3 - 2	93306-005Y3	3 - 24	97027-06025	2 - 16		
J1B-K8271-00	15 - 1	90170-10840	8 - 17	90386-12800	6 - 26	93306-007Y0	8 - 14	97027-06050	2 - 22		
J0B-K8273-10	12 - 22	90176-06008	17 - 8	90387-046N7	4 - 36	93306-203X1	8 - 7		14 - 4		
J0C-K827A-00	13 - 17	90179-05807	23 - 18	90387-12016	3 - 15	93306-20437	3 - 23	97027-08016	22 - 3		
J1D-K8282-00	12 - 12	90179-08261	5 - 7	90387-241M7	3 - 25	93306-303Y6	8 - 10	97027-08020	23 - 3		
J1A-K8297-00	13 - 25	90179-08824	23 - 19	90461-14108	23 - 34	93420-44805	8 - 29	97502-05516	23 - 24		
J1A-K8298-00	13 - 22	90179-12262	9 - 3	90464-20005	23 - 12	93420-50804	8 - 4		23 - 42		
J2B-K8312-00	16 - 3	90183-05008	12 - 16		23 - 29	93900-00825	9 - 2	97512-08530	4 - 30		
J2B-K8313-00	16 - 5	90183-08800	21 - 11	90464-24230	5 - 4	95302-08700	11 - 5	97512-10620	1 - 11		
JD1-K8314-10	16 - 8		21 - 25	90464-32804	21 - 14	95307-08700	5 - 8	97580-06540	19 - 21		
J2B-K831A-00	16 - 6		21 - 34		21 - 28	95602-10200	1 - 14	97602-05225	23 - 26		
J2B-K8328-00	14 - 6		21 - 41		23 - 27		3 - 7	97702-40525	2 - 26		
JPO-K8328-00	16 - 4	90185-12008	4 - 7		23 - 31		11 - 8		4 - 33		
J1B-K832F-00	12 - 27	90201-044H9	4 - 34	90464-70803	23 - 30	95602-12200	1 - 4	98580-06025	14 - 15		
J1B-K832G-00	12 - 28	90201-05824	6 - 55		23 - 32		1 - 8	99002-09600	5 - 10		
JW1-K8340-00	17 - 5	90201-06020	2 - 18	90468-20196	5 - 3		4 - 9				
JW8-K8357-00	4 - 31		2 - 23	90480-13016	21 - 12	95602-14100	3 - 28				
JN6-K8358-01	4 - 32		14 - 13		21 - 26	95612-12100	3 - 18				
J0B-K835E-00	12 - 14		17 - 7		21 - 35	95680-06100	2 - 17				
J1E-K8361-00	19 - 10		19 - 13		21 - 42		2 - 25				
J1E-K8362-00	19 - 14		19 - 17	90502-10013	4 - 35		14 - 7				
J0A-K8401-00	19 - 5	90201-06416	14 - 16	90506-14001	7 - 8		14 - 14				
	19 - 22	90201-068E2	20 - 13		7 - 19	95702-06500	23 - 40				
JW1-K8402-10	19 - 20	90201-121H8	7 - 12	90506-20281	7 - 7	95802-06040	19 - 2				
	19 - 27		7 - 23		7 - 18		19 - 3				
J1E-K8423-00	17 - 1	90201-121H9	7 - 11	91490-25015	5 - 12	95812-06012	12 - 4				
J1B-K8426-00	19 - 18		7 - 22	91490-30030	8 - 27	95812-06025	20 - 11				
J1A-K8427-00	19 - 1	90201-12426	1 - 9	91702-08018	5 - 11	95812-08016	11 - 3				